

VC 5000

 **Warning**

Forward this manual to the person responsible for Installation, Operation and Maintenance of the product described herein. Without access to this information, faulty Installation, Operation or Maintenance may result in personal injury or equipment damage.

Installation, Operation and Maintenance of Airflex[®] VC Element Assemblies



 **Caution:**

Use Only Genuine Airflex[®] Replacement Parts

The Airflex Division of Eaton Corporation recommends the use of genuine Airflex replacement parts. The use of non-genuine Airflex replacement parts could result in substandard product performance, and may void your Eaton warranty. For optimum performance, contact Airflex:

In the U.S.A. and Canada: **(800) 233-5926**
Outside the U.S.A. and Canada: **(216) 281-2211**

August, 1989
(Revised: July, 1995)

203675

© Copyright Eaton Corp., 1995. All rights reserved.

PDF Format

Authorized Distributor



26255 Groesbeck Hwy.
Warren, MI 48089 U.S.A.
586.775.3000 • 586.775.3040 (Fax)
sales@midwestbrake.com
www.midwestbrake.com

Eaton[®] Airflex[®] Clutches & Brakes



**FIG. I- COMPONENT PARTS FOR
AIRFLEX TYPE VC ELEMENT**

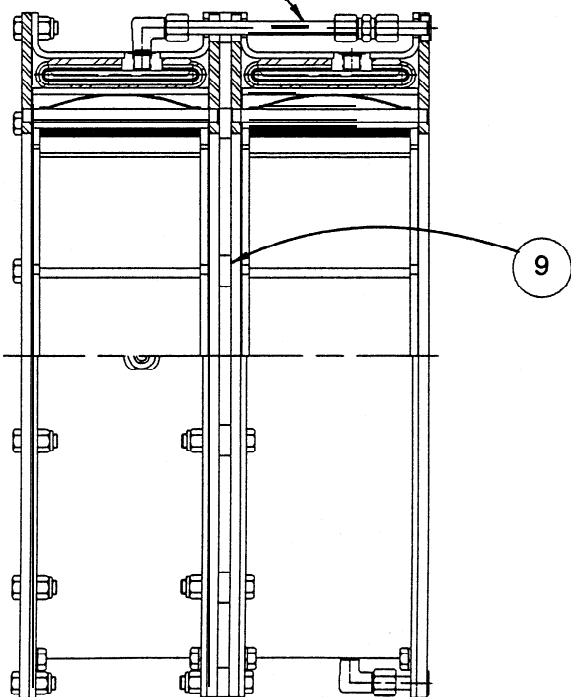
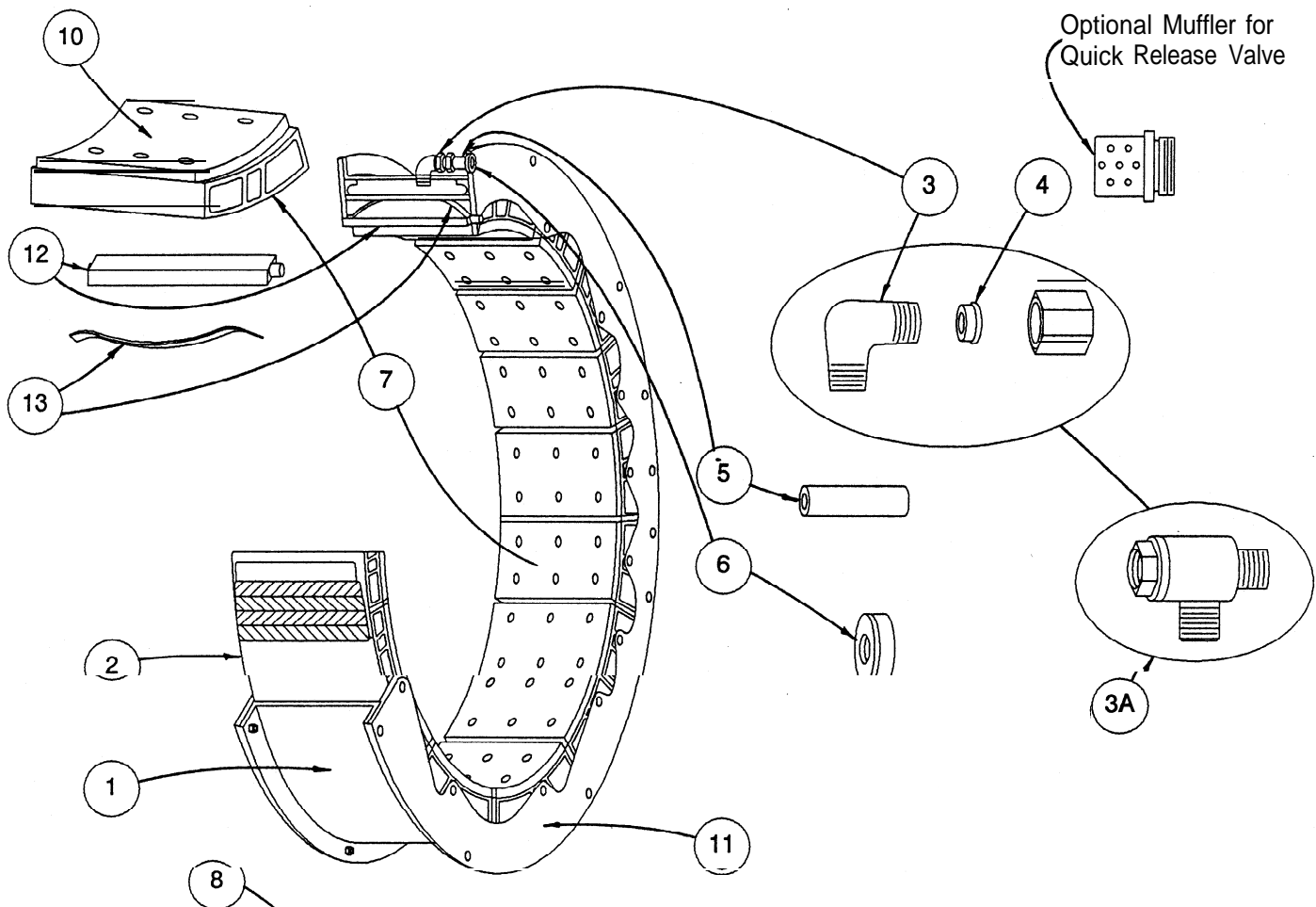



DUAL MOUNTED

ITEM	DESCRIPTION
1	Rim
2	Tube (w/valve stem snap rings where req'd.)
3	Elbow Assembly
3A	Optional - Quick Release Valve Assembly
4	Compression Ring (included-with items 3 & 3A)
5	Air Connection Tube
6	Air Connection Gasket
7	Friction Shoe Assembly
8	Air Tube Group (Dual Mounted)
9	Spacer Group (Dual Mounted)
10	Replacement Friction Lining & Fasteners
11	Side Plate (2 required)
12	Torque Bar
13	Release Spring



1.0 INTRODUCTION

Throughout this manual there are a number of **HAZARD WARNINGS** that must be read and adhered to in order to prevent possible personal injury and/or damage to equipment. Three signal words "**DANGER**", "**WARNING**", and "**CAUTION**" are used to indicate the severity of a hazard, and are preceded by the safety alert symbol .

 **DANGER** - Denotes the most serious hazard, and is used when serious injury or death **WILL** result from misuse or failure to follow specific instructions.

 **WARNING** - Used when serious injury or death **MAY** result from misuse or failure to follow specific instructions.

 **CAUTION** - Used when injury or product/equipment damage may result from misuse or failure to follow specific instructions.

It is the responsibility and duty of all personnel involved in the installation, operation and maintenance of the equipment on which this device is used to fully understand the  **DANGER**,  **WARNING**, and  **CAUTION** procedures by which hazards are to be avoided.

1.1 Description

1.1.1 The Airflex[®] air-actuated VC element assembly is specifically designed and manufactured for severe clutch or brake applications on heavy equipment where high starting loads or sustained slippage would normally lower clutch or brake efficiency and reduce operating life. Constricting action and ventilated construction make high torque capacity and rapid heat dissipation possible.

1.1.2 All Airflex VC element assemblies are supplied with long wearing, NON-ASBESTOS friction material.

1.1.3 Airflex element assemblies are available for drum diameters from 11.5 inches through 66 inches. The element size designation indicates the nominal drum diameter in inches, the clutch model and the width of the friction material. For example, size "38VC1200" indicates the element operates on a drum having a nominal diameter of 38 inches, is an Airflex "VC" series clutch or brake (the scope of this manual) and has friction material which is 12 inches wide.

1.1.4 Where diametral space is limited, or the torque required is greater than a single element can transmit, all sizes of Airflex VC elements can be supplied as dual units.

1.2 How It Works

1.2.1 Referring to Figures 1 and 2, the neoprene and cord actuating tube is contained within a steel rim which is drilled for mounting to the driving component (or reaction bracket in the case of a VC brake application). As air pressure is applied to the air actuating tube, the tube inflates, forcing the friction shoe assemblies uniformly against the drum which is attached to the driven component. The friction shoe assemblies, which consist of friction blocks attached to aluminum backing plates, are guided by torque bars which are secured to side plates. In the case where the VC element is being used as a clutch and is attached to the driving shaft, the torque flow is from the driving shaft, through the element mounting component (typically an iron spider), through the rim/side plate structure, through the torque bars to the backing plates and friction material, where the torque is transmitted through the friction couple to the components mounted on the driven shaft (clutch drum and drum mounting component). As actuating air is exhausted, release springs and centrifugal force assure positive disengagement.

1.3 Element Adjustment

1.3.1 Airflex VC elements are completely self adjusting and automatically compensate for lining and drum wear. Lubrication is not required. The torque developed is dependent upon rotating speed and applied air pressure. By limiting the applied pressure, the element will act as a torque limiting device and provide overload protection.

1.3.2 To accomplish regulated or cushioned engagement of the element, a flow control valve may be installed in the element air supply line and adjusted to restrict air flow to the element while allowing free flow away from the element for rapid disengagement. By adjusting the restricted flow, the rate of engagement may be varied. Note that the flow control valve does not regulate air pressure - the supply pressure must always be adequate to transmit the maximum required torque. Refer to the OPERATION section of this manual for air piping configurations.

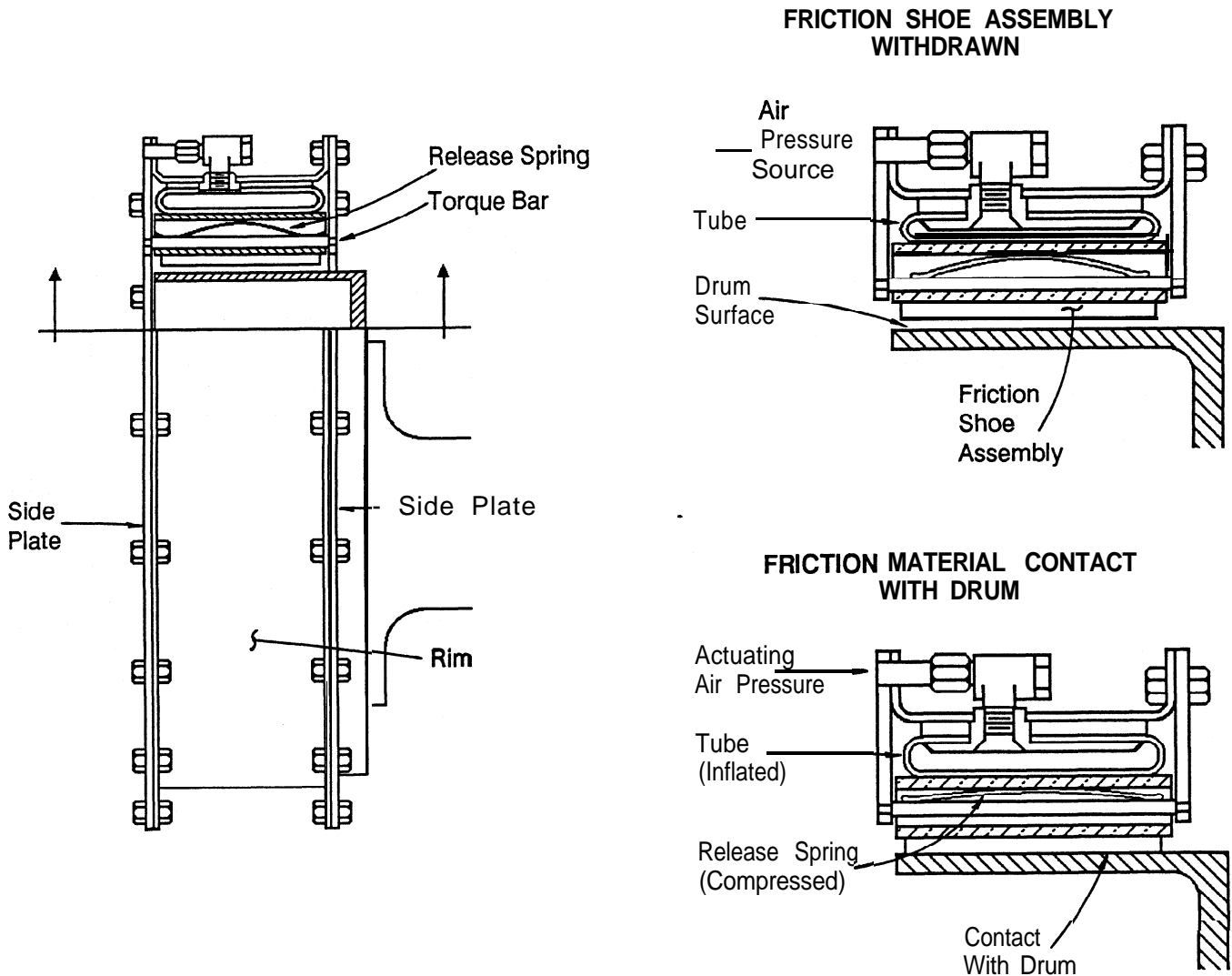

Fig. 2

2.0 INSTALLATION

! Warning:

Only qualified personnel should install, adjust or repair these units. Faulty workmanship will result in exposure to hazardous conditions or personal injury.

! Caution:

Do not inflate the element without having a drum in place. Inflation of the element without a drum in place will result in permanent damage to the element components.

2.1 Mounting Arrangements

- 2.1.1 Figure 3 illustrates the gap-mounting arrangement. In this arrangement, the element is attached to a spider which is typically mounted on the driving shaft. The drum is attached to a drum hub which is typically mounted on the driven shaft. The gap between the two shafts allows the element and drum to be removed without disturbing either shaft.

Note: The text in the Installation, Alignment and Removal sections refer to this type of mounting arrangement.

SINGLE NARROW & SINGLE WIDE

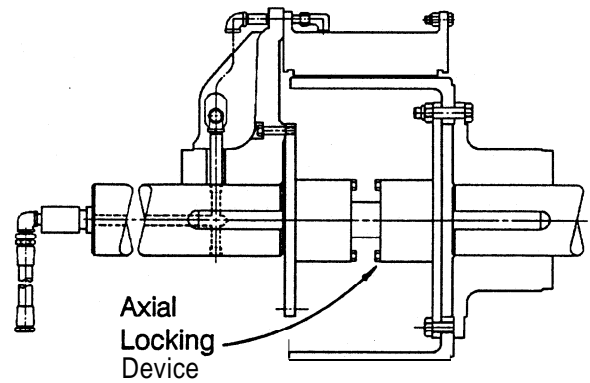
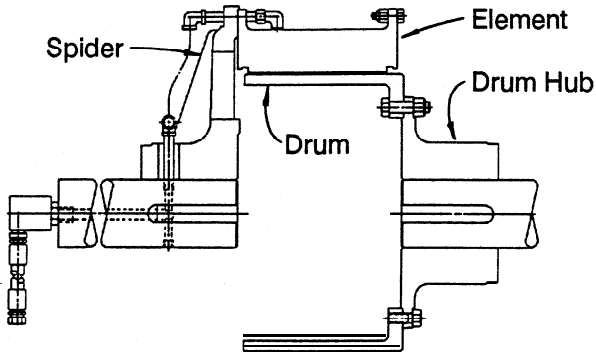
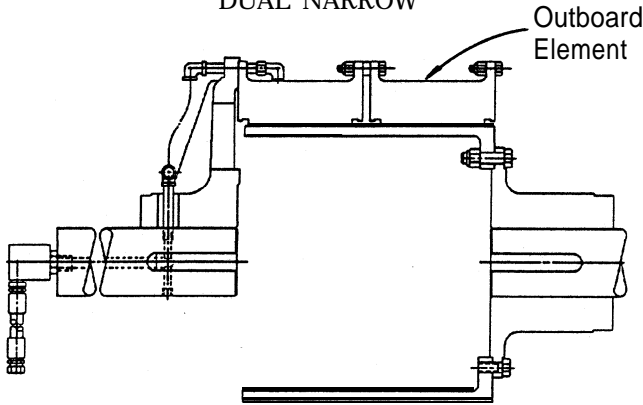

Fig. 4

DUAL NARROW



DUAL WIDE

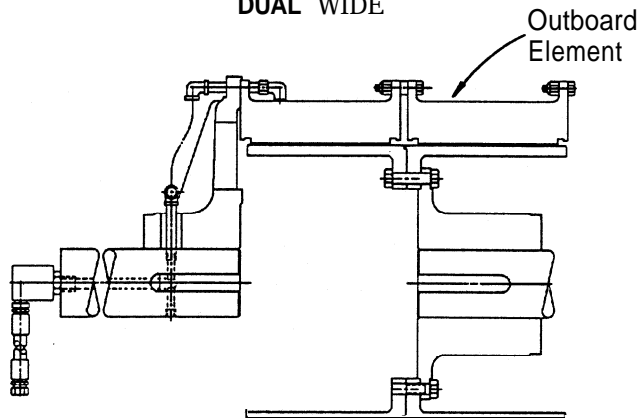

Fig. 3

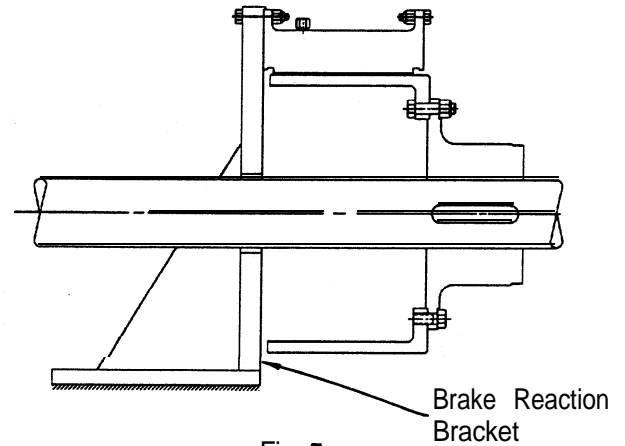

Fig. 5

2.1.2 Figure 4 illustrates the gap-mounting arrangement with an axial locking device. The axial locking device restricts the relative axial motion between the driving and driven shafts. This arrangement is typically used where a synchronous motor armature with plain bearings must be held on magnetic center.

2.1.3 Figure 5 illustrates a typical VC brake application. The drum and drum hub are attached to the shaft which is to be stopped. The element is attached to a rigid reaction bracket.

2.1.4 Figure 6 illustrates a typical marine main propulsion application. In this arrangement, the element is attached to a pinion adapter plate and the drum and drum hub are attached to a quill shaft. A manifold is attached to the outboard end of the element for bearing support of the quill shaft.

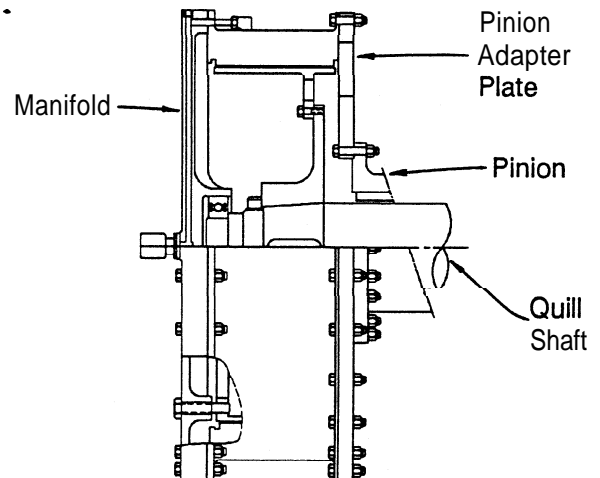

Fig. 6

- 2.15 Figure 7 illustrates a typical marine main propulsion application where the clutch is mounted between the engine and reduction gear. In this arrangement, the VC clutch is combined with a Geislinger® flexible torsional coupling.

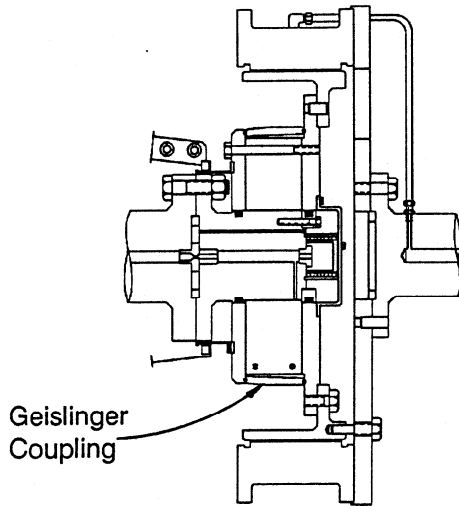

Fig. 7

- 2.1.6 Figure 8 illustrates a VC clutch mounting for punch press applications. The drum and drum hub are attached to the crankshaft or backshaft and the element is attached to a bearing-supported flywheel or bullgear. VC clutches on punch presses are typically used in combination with Air-flex type CTE and DBA brakes.

- 2.1.7 Airflex can provide specific drawings covering the different mounting arrangements mentioned. The maintenance of the element assembly, tolerances and wear limits of friction material, and alignment specifications in this manual apply to all VC applications.

2.2 Mounting Considerations

- 2.2.1 For clutch and brake applications, shaft alignment must be within the tolerances indicated in the Alignment section of this manual.

! Caution:

Operation with shaft misalignment exceeding the limits indicated in the Alignment section of this manual will result in accelerated wear of the element components. Severe misalignment will result in excessive vibration and/or overheating when disengaged due to dragging of the friction shoes.

- 2.2.2 The element must be protected from contamination from oil, grease or excessive amounts of dust.

! Caution:

Oil or grease contamination will result in a reduction of developed clutch or brake torque. Excessive dust contamination may result in incomplete disengagement. Either of these conditions will result in clutch or brake slippage and overheating.

! Caution:

All rotating equipment must be guarded to comply with applicable safety standards.

- 2.2.3 All mounting fasteners must be of the proper size and grade, and torqued to the appropriate value. See Table 1.

! Warning:

Use only the proper grade and number of mounting fasteners. Using commercial grade fasteners (Grade 2) in place of Grade 8 fasteners (where called for) may result in failure under load, causing personal injury or equipment damage.

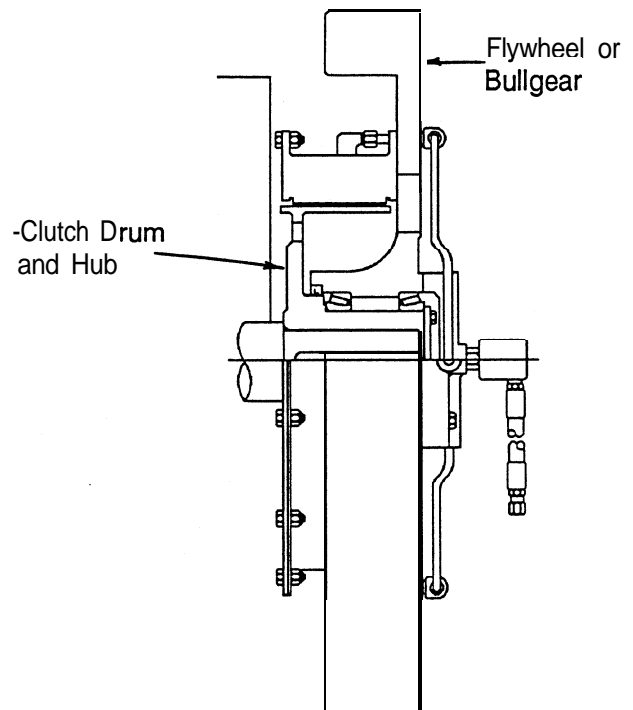

Fig. 8

TABLE 1 - FASTENER ASSEMBLY TORQUE

SN = SINGLE NARROW
 SW = SINGLE WIDE
 DN = DUAL NARROW
 DW = DUAL WIDE
 L = LUBED TORQUE - FT.-LB. (Nm) (30 WT. MOTOR OIL OR ANTI-SEIZE)
 D = DRY TORQUE - FT.-LB. (Nm)

SIZE	ELEMENT TO SPIDER/ SIDE PLATE TO RIM	TORQUE	DRUM TO HUB	TORQUE
SN11.5VC500	3/8-16NC GR 2	D 15 (20)	1/2-13NC GR 2	D 38 (51)
SN14VC500	1/2-13NC GR 2	D 38 (51)	1/2-13NC GR 2	D 38 (51)
SN16VC600	1/2-13NC GR 2	D 38 (51)	3/4-10NC GR 2	L 93 (126)
SN20VC600	1/2-13NC GR 2	D 38 (51)	3/4-10NC GR 2	L 93 (126)
SN24VC650	5/8-11NC GR 2	D 77 (104)	3/4-10NC GR 2	L 93 (126)
SN28VC650	5/8-11NC GR 2	D 77 (104)	3/4-10NC GR 2	L 93 (126)
SN33VC650	3/4-10NC GR 2	L 93 (126)	3/4-10NC GR 2	L 93 (126)
SN37VC650	3/4-10NC GR 2	L 93 (126)	3/4-10NC GR 2	L 93 (126)
SN42VC650	3/4-10NC GR 2	L 93 (126)	3/4-10NC GR 2	L 93 (126)
DN11.5VC500	3/8-16NC GR 2	D 15 (20)	1/2-13NC GR 8	D 109 (148)
DN14VC500	1/2-13NC GR 8	D 87 (118)	1/2-13NC GR 2	D 38 (51)
DN16VC600	1/2-13NC GR 2	D 38 (51)	3/4-10NC GR 8	L 245 (332)
DN20VC600	1/2-13NC GR 8	D 87 (118)	3/4-10NC GR 8	L 211 (286)
DN24VC650	5/8-11NC GR 2	D 77 (104)	3/4-10NC GR 2	L 93 (126)
DN28VC650	5/8-11NC GR 2	D 77 (104)	3/4-10NC GR 2	L 93 (126)
DN33VC650	3/4-10NC GR 2	L 93 (126)	3/4-10NC GR 2	L 93 (126)
DN37VC650	3/4-10NC GR 2	L 93 (126)	3/4-10NC GR 2	L 93 (126)
DN42VC650	3/4-10NC GR 2	L 93 (126)	3/4-10NC GR 2	L 93 (126)
SW14VC1000	1/2-13NC GR 2	D 38 (51)	1/2-13NC GR 8	L 109 (148)
SW16VC1000	1/2-13NC GR 2	D 38 (51)	3/4-10NC GR 2	L 93 (126)
SW20VC1000	1/2-13NC GR 2	D 38 (51)	3/4-10NC GR 2	L 93 (126)
SW24VC1000	5/8-11NC GR 2	D 77 (104)	3/4-10NC GR 2	L 93 (126)
SW28VC1000	5/8-11NC GR 2	D 77 (104)	3/4-10NC GR 2	L 93 (126)
SW32VC1000	5/8-11NC GR 2	D 77 (104)	3/4-10NC GR 2	L 93 (126)
SW38VC1200	3/4-10NC GR 2	L 93 (126)	3/4-10NC GR 2	L 93 (126)
SW42VC1200	3/4-10NC GR 2	L 93 (126)	3/4-10NC GR 2	L 93 (126)
SW46VC1200	7/8-9NC GR 2	L 109 (148)	1-8NC GR 2	L 163 (221)
SW52VC1200	7/8-9NC GR 2	L 109 (148)	1-8NC GR 2	L 163 (221)
SW51VC1600	7/8-9NC GR 2	L 109 (148)	1-8NC GR 2	L 163 (221)
SW60VC1600	1-8NC GR 2	L 163 (221)	1 1/2-6NC GR 2	L 566 (767)
SW66VC1600	1 1/4-7NC GR 2	L 325 (441)	1 1/2-6NC GR 2	L 566 (767)
DW16VC1000	1/2-13NC GR 8	D 87 (118)	3/4-10NC GR 8	L 245 (332)
DW20VC1000	1/2-13NC GR 8	D 87 (118)	3/4-10NC GR 8	L 245 (332)
DW24VC1000	5/8-11NC GR 8	D 174 (236)	3/4-10NC GR 8	L 245 (332)
DW28VC1000	5/8-11NC GR 8	D 174 (236)	3/4-10NC GR 8	L 245 (332)
DW32VC1000	5/8-11NC GR 8	D 174 (236)	3/4-10NC GR 8	L 245 (332)
DW38VC1200	3/4-10NC GR 8	L 245 (332)	3/4-10NC GR 8	L 245 (332)
DW42VC1200	3/4-10NC GR 8	L 245 (332)	3/4-10NC GR 8	L 245 (332)
DW46VC1200	7/8-9NC GR 2	L 109 (148)	1-8NC GR 8	L 510 (692)
DW52VC1200	7/8-9NC GR 2	L 109 (148)	1-8NC GR 8	L 510 (692)
DW51VC1600	7/8-9NC GR 2	L 109 (148)	1-8NC GR 8	L 510 (692)
DW60VC1600	1-8NC GR 2	L 163 (221)	1 1/2-6NC GR 2	L 566 (767)
DW66VC1600	1 1/4-7NC GR 2	L 325 (441)	1 1/2-6NC GR 2	L 566 (767)

HEX SIZES (in.)

SIZE	BOLT	NUT	SIZE	BOLT	NUT	SIZE	BOLT	NUT
3/8NC	9/16	9/16	3/4NC	1-1/8	1-1/16	1-1/4NC	1-7/8	1-13/16
1/2NC	3/4	3/4	7/8NC	1-5/16	1-1/4	1-1/2NC	2-1/4	2-3/16
5/8NC	15/16	15/16	1NC	1-1/2	1-7/16			

2.3 Mounting Spider and Drum Hub

- 2.3.1 The spider and drum hub are bored for a press fit onto their respective shafts. The interference is approximately .0005 in. per inch (.0005mm/mm) of shaft diameter.
- 2.3.1.1 Ensure the shaft is clean and free of nicks or burrs and check the shaft and bore diameters for proper fit.
- 2.3.1.2 Tap the key into the keyway, making sure it bottoms.
- 2.3.1.3 Apply a light coat of anti-seizing compound to the shaft and key.
- 2.3.1.4 Heat the drum hub or spider uniformly to 250°F (121°C) to expand the bore.



Caution:

It is recommended the drum hub or spider be heated in oil or an oven; however, since this is not always possible, torches may be used. When using torches, use several with "rosebud" (broad-flame) tips and keep them moving to avoid "hot spots". Check bore temperature frequently to avoid overheating.

- 2.3.1.5 Slide the heated drum hub or spider onto the shaft until the hub face is flush with the end of the shaft. Hold in position and allow to cool.

2.4 Shaft Alignment

Note: The text in this section applies to gap-mounted applications; however, the alignment tolerances apply to all types of mountings.

Parallel Alignment Tolerance (Off set):

Not to exceed 0.010 inch (.254mm) Total Indicator Reading (0.005 in. (.127mm) maximum offset).

Angular Alignment Tolerance (Gap):

Not to exceed 0.0005 inch per inch (.0005mm/mm) diameter at which readings are taken ("D" on Fig. 9).

Note: The alignment procedure described below has been used successfully on many VC clutch and brake applications. Other procedures, of course, may be used; however, the alignment tolerances are the same regardless of the technique used.

- 2.4.1 Foundations must be set so distance "X", shown on Figure 9, is established. If the clutch is mounted on a shaft having plain bearings, make sure the shaft is centered within the bearings when establishing the "x" dimension. Refer to Table 2 for appropriate "X" dimensions.

Note: It is presumed that one of the shafts has been properly located and anchored.

TABLE 2 - "X" DIMENSIONS (FIG. 9)

SIZE	"X" in. (mm)	SIZE	"X" in. (mm)	SIZE	"X" in. (mm)	SIZE	"X" in. (mm)
SN11.5VC500	6.750 (171.5)	DN11.5VC500	13.375 (339.7)	SW14VC1000	11.875 (301.6)	DW16VC1000	12.750 (323.9)
SN14VC500	6.812 (173.0)	DN14VC500	13.438 (341.3)	SW16VC1000	11.875 (301.6)	DW20VC1000	12.750 (323.9)
SN16VC600	8.062 (204.8)	DN16VC600	15.938 (404.8)	SW20VC1000	11.875 (301.6)	DW24VC1000	12.750 (323.9)
SN20VC600	8.062 (204.8)	DN20VC600	15.938 (404.8)	SW24VC1000	11.875 (301.6)	DW28VC1000	12.750 (323.9)
SN24VC650	8.562 (217.5)	DN24VC650	16.688 (423.9)	SW28VC1000	11.875 (301.6)	DW32VC1000	12.812 (325.4)
SN28VC650	8.562 (217.5)	DN28VC650	16.688 (423.9)	SW32VC1000	11.938 (303.2)	DW38VC1200	15.000 (381.0)
SN33VC650	8.562 (217.5)	DN33VC650	16.750 (425.5)	SW38VC1200	14.125 (358.7)	DW42VC1200	15.125 (384.2)
SN37VC650	8.562 (217.5)	DN37VC650	16.750 (425.5)	SW42VC1200	14.125 (358.7)	DW46VC1200	15.250 (387.4)
SN42VC650	8.562 (217.5)	DN42VC650	16.750 (425.5)	SW46VC1200	14.125 (358.7)	DW52VC1200	15.750 (400.0)
				SW52VC1200	14.625 (371.5)	DW51VC1600	20.000 (508.0)
				SW51VC1600	18.875 (479.4)	DW60VC1600	20.375 (517.5)
				SW60VC1600	18.750 (476.3)	DW66VC1600	22.000 (558.8)
				SW66VC1600	20.500 (520.7)		

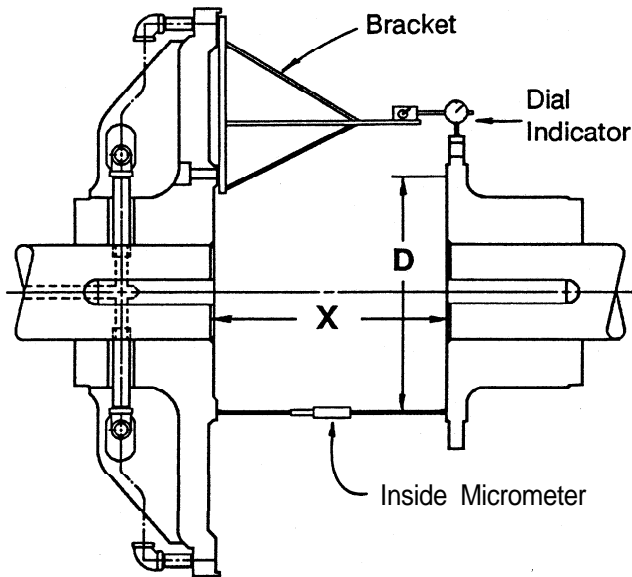

Fig. 9

- 2.4.2 Fabricate a rigid bracket for supporting a dial indicator and attach to the spider. See Figure 9.
- 2.4.3 Thoroughly clean the flange O.D. and the face of the drum hub where alignment readings are to be taken.
- 2.4.4 Rotate the spider and take parallel alignment readings off the drum hub flange O.D. If both shafts can be rotated together, the alignment readings are less influenced by any surface irregularities.

! Caution:

When recording parallel alignment readings, "sag" of the indicator/indicator bracket must be accounted for.

- 2.4.5 Angular alignment readings can be made by accurately measuring the gap between the spider and drum hub faces with an inside micrometer. If a dial indicator is used, make sure to monitor and correct for any axial movement of the shaft. To reduce the influence any surface irregularities may have on the angular alignment readings, index the spider 90 degrees after taking the initial set of readings. Take an additional set of readings and index the spider another 90 degrees. Continue in this manner until four sets of readings have been taken. For misalignment correction, use the average of the four readings at each position. In other words, average the four top readings, the four bottom readings, and each of the four side readings.

- 2.4.6 Shim and shift the base of the movable shaft to correct the misalignment. After tightening the base, recheck the alignment and correct if necessary. Make sure to check for a "soft foot" condition. Dowel or chock into position after satisfactory alignment has been achieved.

Note: On many applications, thermal growth of the driving or driven machinery may result in unacceptable shaft alignment in a running condition. It is always good practice to make a "hot" alignment" check and re-shim if necessary.

2.5 Installation of Element and Drum (Narrow, Dual Narrow and Single Wide)

- 2.5.1 Note the orientation of the drum flange with respect to the air connection(s) on the element and slide the drum into the element.
- 2.5.2 Separate the shafts as far as the bearing clearances will allow and hoist the element/drum into position.
- 2.5.3 Attach the drum to the drum hub with the appropriate fasteners. See Table 1. Make sure the bore in the drum flange fully engages the pilot on the drum hub.

! Warning:

Use only the proper grade and number of fasteners. Using commercial grade fasteners (Grade 2) in place of Grade 8 fasteners (where called for) may result in failure of the fasteners under load, causing personal injury or equipment damage.

- 2.5.4 Install the air connection gaskets onto the air tubes. The metal backup washer is to be positioned toward the elbow (away from the spider). See Figure 10.

Note: Some older elements use a flanged air connection tube and a thin gasket. See Table 3 for correct part numbers.

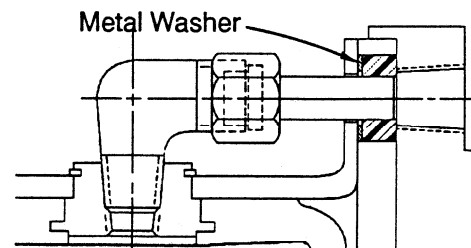
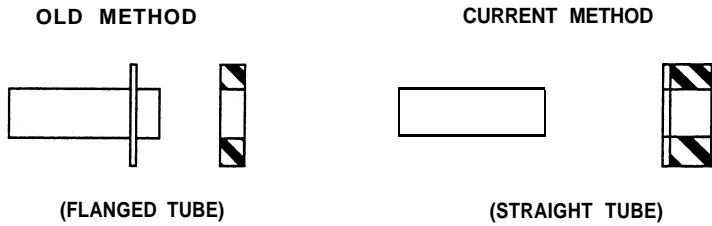

Fig. 10

TABLE 3 - AIR CONNECTIONS FOR VC ELEMENTS



SIZE	AIR TUBE	WASHER	AIR TUBE	WASHER
11.5VC500	201402	72x15	412178-02	412324-01
14VC500	201302	72x11	412178-03	412324-02
16VC600	201302	72x11	412178-03	412324-02
20VC600	201302	72x11	412178-03	412324-02
24VC650	201286	72x12	412178-05	412324-03
28VC650	201286	72x12	412178-05	412324-03
33VC650	201284	72x13	412178-06	412324-04
37VC650	201284	72x13	412178-06	412324-04
42VC650	201284	72x13	412178-06	412324-04
14VC1000	201302	72x11	412178-03	412324-02
16VC1000	202408	72x11	412178-03	412324-02
20VC1000	201302	72x11	412178-03	412324-02
24VC1000	201286	72x12	412178-05	412324-03
28VC1000	201286	72x12	412178-05	412324-03
32VC1000	201286	72x12	412178-05	412324-03
38VC1200	201284	72x13	412178-06	412324-04
42VC1200	201284	72x13	412178-06	412324-04
46VC1200	202081	72x13	412178-07	412324-04
52VC1200	202751	72x14	412178-08	412324-05
51VC1600	304213	72x14	412178-09	412324-05
60VC1600	304213	72x14	412178-18	412324-06
66VC1600			412178-04	412324-06

2.5.5 Align the element air connections with the passages in the spider and attach the element to the spider with the appropriate fasteners. See Table 1. Make sure the element fully engages the register in the spider.



Warning:
Use only the proper grade and number of fasteners. Using commercial grade fasteners (Grade 2) in place of Grade 8 fasteners may result in failure of the fasteners under load, causing personal injury or equipment damage.

2.6 Installation of Element and Drums (Dual Wide)

2.6.1 Separate the shafts as far as the bearing clearances will allow.

2.6.2 Attach the drum having the female register on the drum flange to the drum hub with screws and lockwashers. There are tapped holes in the drum flange to accept the screws. Make sure the bore in the drum flange fully engages the pilot on the drum hub. See Figure 3.

2.6.3 Disassemble the dual element into two halves and, noting the orientation of the air connections, place the element onto the drum installed in 2.6.2.

2.6.4 Noting the orientation of the flange on the remaining drum with respect to the air connections on the remaining element, slide the drum into the element.

2.6.5 Hoist the element/drum into position, align the tapped holes in the drum having the male pilot with the tapped holes in the drum attached to the drum hub, and attach both drums to the drum hub with the appropriate fasteners. See Table 1. Make sure the male pilot fully engages the female register.



Warning:
Use only the proper grade and number of fasteners. Using commercial grade fasteners (Grade 2) in place of Grade 8 fasteners (where called for) may result in failure of the fasteners under load, causing personal injury or equipment damage.

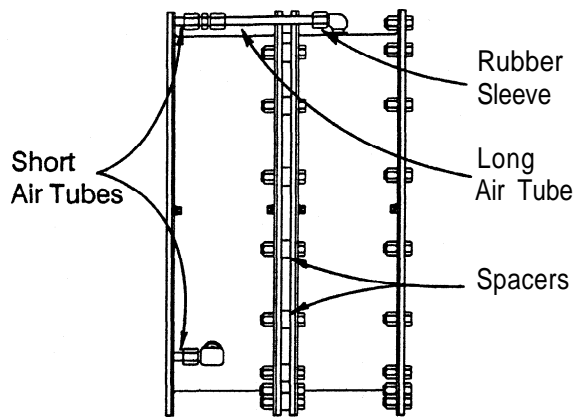

Fig. 11

2.6.6 Align the air connections and reassemble the element halves, making sure the spacers are in place between the elements. See Figure 11.

2.6.7 Reassemble the air connection tubes. If an elbow has been removed, use a good quality pipe sealant on the threads. See Figure 11.

Note: The elbow assemblies on the outboard element (farthest from the spider) use rubber compression sleeves. Make sure the sleeves are securely on the long air tubes.

2.6.8 Install the air connection gaskets onto the air tubes. The metal backup washer is to be positioned toward the elbow (away from the spider). See Figure 10.

2.6.9 Align the element air connections with the corresponding passages in the spider and attach the element to the spider with the appropriate fasteners. See Table 1. Make sure the element fully engages the register in the spider.

! Warning:

Use only the proper grade and number of fasteners. Using commercial grade fasteners (Grade 2) in place of Grade 8 fasteners may result in failure of the fasteners under load, causing personal injury or equipment damage.

2.7 Air Control System

2.7.1 A typical air control system is shown on Figure 12. Since the air control system used will be dependent on the specific application, a detailed description cannot be made in this manual. Following are some general guidelines for installing and adjusting air controls.

2.7.1.1 The air receiver tank must be located as close to the rotorseal as possible (within five feet) for consistent clutch or brake response.

2.7.1.2 Use full size piping and valves consistent with the rotorseal size.

2.7.1.3 Keep the number of elbows to a minimum.

2.7.1.4 Use poppet-type solenoid valves. Spool valves are not recommended.

2.7.1.5 An air line lubricator is not required for the element; however, if one is used, it must be a non-adjustable, mist-type.

2.7.1.6 If a flow control valve is used, it must have free flow (indicated by an arrow on the valve body) directed away from the element.

2.7.1.7 The final connection to the rotorseal MUST be made with flexible hose and place no radial load upon the rotorseal.

! Caution:

Do not use rigid pipe at the connection to the rotorseal. Rigid piping will result in excessive loads on the rotorseal bearings, shortening life.

! Caution:

Maximum applied air pressure is 125 psig (8.5 bar). Operation at pressures exceeding 125 psig may result in damage to the element. Consult the factory if operation at pressures greater than 125 psig is desired.

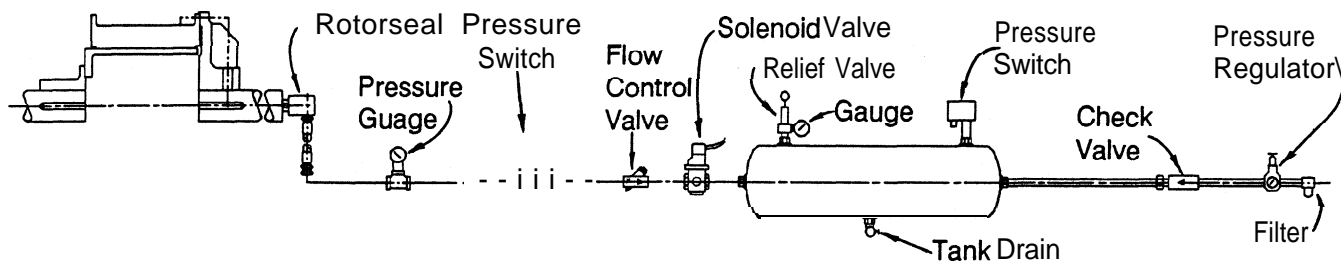

Fig. 12

TABLE 4 - MAXIMUM SAFE OPERATING SPEEDS

Size (Narrow)	Maximum RPM	Size (Narrow)	Maximum RPM	Size (Wide)	Maximum RPM	Size (Wide)	Maximum RPM
11.5VC500	1800	28VC650	1000	14VC1000	1800	42VC1200	670
14VC500	1500	33VC650	900	16VC1000	1400	46VC1200	600
16VC600	1400	35VC650	900	20VC1000	1300	52VC1200	550
20VC600	1200	37VC650	800	24VC1000	1250	51VC1600	550
24VC650	1050	42VC650	800	28VC1000	1100	60VC1600	520
				32VC1000	1050	66VC1600	520
				38VC1200	740		

3.0 OPERATION

Warning:

Exceeding the operating limits described in this section may result in personal injury or equipment damage.

3.1 Torque, RPM and Pressure Limits

3.1.1 The developed torque is directly proportional to the applied air pressure. If the developed torque seems inadequate, check for oil, grease or dust contamination.

Caution:

Maximum applied air pressure is 125 psig (8.5 bar). Operation at pressures exceeding 125 psig may result in damage to the element. Consult the factory if operation at pressures greater than 125 psig is desired.

Caution:

The non-asbestos friction material used in Airflex VC units may not develop rated torque initially, as a short "wear in" period is required. It is very important that clutch or brake operation be monitored closely to prevent excessive heat generation from slippage.

3.1.2 Maximum safe operating speeds are shown on Table 4.

Danger:

Do not exceed the operating speeds shown on Table 4. Operation at speeds greater than allowable will result in permanent damage to the element, personal injury or death.

4.0 MAINTENANCE

Warning:

Only qualified personnel should maintain and repair these units. Faulty workmanship may result in personal injury or equipment damage.

Caution:

When replacing clutch or brake components, use only genuine, Airflex replacement parts.

4.1 Periodic Inspection

4.1.1 The following items may be inspected without disassembly of the element:

4.1.1.1 **Friction Shoe Assembly Lining Wear** - Check the lining thickness and compare to the values shown on Table 5. If the linings have worn to minimum allowable thickness or less, they must be replaced as a complete set.

Caution:

Operation with friction material worn to less than minimum allowable thickness will result in damage to the drum.

Note: A wear indicating groove (see figure below) is provided on each end of the friction block. The maximum wear point, which coincides with the values shown on Table 5, is at the bottom of the groove.

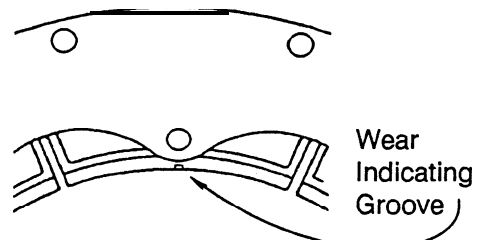

TABLE 5 FRICTION MATERIAL THICKNESSES		
NARROW SERIES		
Element Size	Minimum Allowable Lining Thickness, in. (mm)	Original Lining Thickness, in. (mm)
11.5VC500 thru 20VC600	.15 (3,8)	.33 (8,4)
24VC650 thru 28VC650	.15 (3,8)	.45 (11,4)
33VC650 thru 42VC650	.28 (7,1)	.58 (14,7)
WIDE SERIES		
12VCI000 thru 20VCI000	.15 (3,8)	.33 (8,4)
24VCI000 thru 28VCI000	.15 (3,8)	.45 (11,4)
32VCI000 thru 42VC1200	.38 (9,5)	.58 (14,7)
46VC1200 and 52VC1200	.38 (9,5)	.69 (17,5)
51,60, and 66 VC1600	.30 (7,6)	.67 (17,0)

4.1.1.2 **Contamination of Shoes or Drum** - Oil or grease contamination will reduce the developed torque of the clutch or brake. Disassembly will be required to clean any oil or grease build-up. In extremely dusty environments, dust may accumulate in the backing plate cavities to the point where the friction shoes will not properly retract. Dust accumulations may be vacuumed out of the cavities.

 **Caution:**

Do not attempt to use a solvent to remove oil or grease without first removing the element. While squirting a solvent into an installed clutch or brake may improve performance temporarily, a fire hazard exists from the heat generated during slippage.

 **Caution:**

Do not use compressed air to blow dust accumulations out of the backing plates. Although the friction material does not contain asbestos, the dust created as the friction material wears, along with the dust from the operating environment, may irritate the respiratory system.

4.1.1.3 **Air Control Components** - Check for proper adjustment of the air control components. Make sure the safety pressure switches, if used, are set correctly. Repair any air leaks as discovered.

4.1.2 Partial or complete disassembly is required to inspect the following items:

4.1.2.1 **Drum Diameter Wear** - Check the O.D. of the drum and compare to the values shown on Table 6. Minor heat-checking may be removed by machining the drum O.D. If the drum has been subjected to excessive heat, the open end may flare out, giving the impression that the drum has not worn. It is therefore important to check the diameter at several locations across the face.

 **Caution:**

Operation of the clutch or brake on a drum that has worn or has been machined to less than minimum allowable diameter will result in damage to the element components.

TABLE 6 DRUM WEAR LIMITS	
NARROW SERIES	
Element Size	Maximum Allowable Wear on Drum Diameter * in. (mm)
11.5VC500 thru 16VC600	.09 (2)
20VC600 thru 24VC650	.12 (3)
28VC650	.19 (5)
33VC650 thru 42VC650	.19 (5)
WIDE SERIES	
12VCI000 thru 16VCI000	.09 (2)
20VCI000 thru 24VCI000	.13 (3)
28VCI000	.19 (5)
32VCI000 thru 38VC1200	.19 (5)
42VC1200 thru 46VC1200	.25 (6)
52VC1200 thru 66VC1600	.25 (6)

* Note: The number preceding the letters "VC" in the element size designates the original drum diameter in inches.

Example: 16VC600 - Original Drum Diameter = 16.00 inches (406mm).
Minimum allowable drum diameter is:
16(406) - .09(2) = 15.91(404).

4.1.2.2 **Air Actuating Tube** - Check that the tube has not been damaged by excessive heat. If any portion of the tube is hard or charred, the tube must be replaced. Check for any blisters, which would indicate ply separation. A tube in this condition must also be replaced.

- 4.1.2.3 **Friction Shoe Lining Wear** - If the linings are glazed, they may be lightly sanded to remove the glazing PROVIDING THEY DO NOT CONTAIN ASBESTOS.



Warning:

Clean the edge of the lining and note the presence of a blue stripe and a white stripe along with brass flakes in the friction material. If the above exists, the linings contain asbestos. Using the appropriate precautions for working with asbestos, remove the linings and dispose of properly. **DO NOT ATTEMPT TO SAND FRICTION MATERIAL CONTAINING ASBESTOS.**



Caution:

When working with any friction material, regardless of whether or not it contains asbestos, always wear approved safety equipment.

- 4.1.2.4 **Uneven Friction Lining Wear** - Tapered wear across the friction surface typically indicates a worn drum and/or misalignment. If two or more adjacent shoes are worn on one end only, the air actuating tube has most likely developed a ply separation at that location.
- 4.1.2.5 **Backing Plate Wear** - Wear on the ends of the backing plates from bearing against the side plates is indicative of misalignment or thrusting. If wear is on one end only, and uniform for all backing plates, a worn drum may be causing the shoes to thrust as the element engages. If wear exists on both ends of all of the backing plates, excessive misalignment is probably the cause. Slight notching in the torque bar cavity is normal; however, if the notching occurs in a short amount of time, check shaft alignment. If both walls in the torque bar cavity are notched, there may be a significant vibration (torsional) problem.
- 4.1.2.6 **Release Springs and Torque Bars** - Excessive wear at the ends of the torque bars where the release spring rides indicates excessive parallel misalignment.
- 4.1.2.7 **Side Plates** - Any wear on the backing plates will also be reflected as elongation of the torque bar holes in the side plates.

- 4.1.2.8 **Contamination of Friction Shoes** - Mild oil or grease contamination may be removed with a solvent. Linings which have become saturated must be replaced. Also, linings that have been charred from excessive heat must be replaced.



Caution:

When using any solvent, always follow the appropriate safety precautions.

- 4.1.2.9 **Excessive Dust Accumulation** - If dust becomes packed in the backing plate cavities, a pressurized enclosure should be considered. Excessive accumulations will prevent complete shoe retraction.

4.2 Removal of Element Assembly and Drum (Narrow, Dual Narrow and Single Wide)



Warning:

Prior to removal of the clutch or brake, make sure the machinery is in, and will remain in, a safe condition.

- 4.2.1 Match mark the element to the spider and the drum to the drum hub.
- 4.2.2 Disconnect the element from the spider and allow it to rest on the drum.
- 4.2.3 Connect an overhead support to the element and apply enough tension to support the weight of the element and drum.
- 4.2.4 Remove the fasteners attaching the drum to the drum hub and hoist the element/drum out from between the shafts.



Caution:

Use extreme care when disconnecting the drum from the hub. Shear points exist at the mounting holes.

4.3 Removal of Element Assemblies and Drums (Dual Wide)

- 4.3.1 Match mark the element assemblies to each other and to the spider. Also, match mark the drums to each other and to the drum hub.

- 4.3.2 Disconnect the dual element from the spider and allow it to rest on the drums. Remove the air connection tubes.
- 4.3.3 Remove the fasteners and spacers attaching the element halves together.
- 4.3.4 Attach an overhead support to the spider side element and apply enough tension to support the weight of the element half and one of the drums.
- 4.3.5 Remove the through bolts and nuts attaching the drums to the drum hub. **DO NOT REMOVE THE SHORT SCREWS AND LOCKWASHERS WHICH HOLD THE FEMALE DRUM ONTO THE DRUM HUB.** Carefully hoist the spider-side element and drum out from between the shafts.
- 4.3.6 Attach an overhead support to the remaining element and apply enough tension to support the weight of the element and drum.
- 4.3.7 Remove the short screws and lockwashers holding the drum onto the drum hub and carefully hoist the element and drum out from between the shafts.

! Caution:

Use extreme care when disconnecting the drums from the drum hub. Shear points exist at the mounting holes.

4.4 Removal of Spider and Drum Hub

- 4.4.1 Puller holes are provided for removal. It will usually require heating along with the puller. When heating, heat uniformly to prevent hot spots.

4.5 Disassembly of the Element

- 4.5.1 Lay the element flat on a clean work surface.
- 4.5.2 Remove the side plate and clean for reassembly. If the torque bar holes are elongated more than one-half the diameter of the pin on the end of the torque bar, the side plate must be replaced.
- 4.5.3 Remove the friction shoe assemblies, torque bars and release springs. If the torque bars and springs come out of the element with the friction shoe assemblies, carefully tap them out of the backing plate cavities. Note wear and replace as necessary.

! Caution:

Whenever the element is removed and disassembled, it is always good practice to replace the release springs.

- 4.5.4 Remove the air connection elbows and spiral snap rings which secure the air actuating tube to the rim. Smaller size elements do not use snap rings. Carefully remove the air actuating tube from the rim and thoroughly inspect. Replace if necessary.

Note: The snap rings may no longer be required on certain size elements. Also, rims manufactured before 1984 were counterbored at the tube valve hole to accept the snap ring. This counterbore has been eliminated, and a second snap ring groove has been added to the tube valve. See Figure 13.

- 4.5.5 Remove the remaining side plate only if it is to be replaced.

Snap ring and Counterbore Eliminated

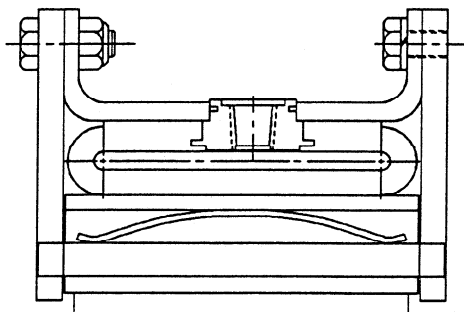

- | | | | |
|-----------|---------|----------|----------|
| 11.5VC500 | 24VC650 | 42VC650 | 24VC1000 |
| 14VC500 | 28VC650 | 14VC1000 | 28VC1000 |
| 16VC600 | 33VC650 | 16VC1000 | 32VC1000 |
| 20VC600 | 37VC650 | 20VC1000 | |

Counterbore Eliminated and Second Snap Ring Groove Added

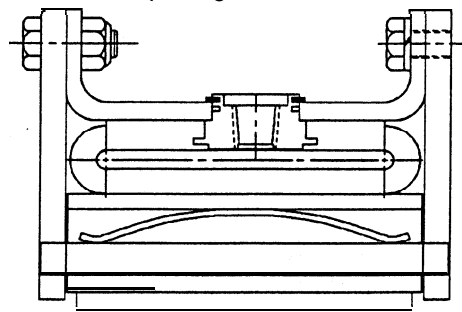

- | | | |
|----------|----------|----------|
| 38VC1200 | 46VC1200 | 51VC1600 |
| 42VC1200 | 52VC1200 | 60VC1600 |
| | | 66VC1600 |

Fig. 13

4.6 Friction Lining Replacement



Caution:

Use only genuine Airflex replacement parts.

- 4.6.1 Make sure the torque bars and release springs have been removed from the backing plates.
- 4.6.2 For riveted friction shoe assemblies, drill the rivets with a 15/64" (6mm) drill and tap the rivet body out. Larger elements have linings attached with flat head screws and locknuts. Air-flex special wrench p/n **304572** will aid in holding the locknuts during removal. See Table 7.

TABLE 7 FRICTION SHOE ASSEMBLY FASTENERS			
DRIVE PIN RIVETS			
11.5VC500	24VC650	42VC650	24VC1000
14VC500	28VC650	14VC1000	28VC1000
16VC600	33VC650	16VC1000	
20VC600	37VC650	20VC1000	
FLAT HEAD SCREWS* (BRASS) AND LOCKNUTS			
32VC1000	42VC1200	52VC1200	60VC1600
38VC1200	46VC1200	51VC1600	66VC1600
* Screws are 3/8-16NC-2 x 1.25 long flat head			

- 4.6.3 Attach the new lining to the backing plate with new screws and locknuts or drive pin rivets (See Figure 14), as applicable. Work from the center of the friction lining out to the ends. The rivets are installed by driving the pin flush with the head.

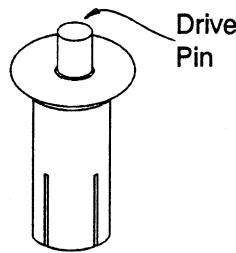

Fig. 14

4.7 Assembly of the Element

- 4.7.1 Make sure that all of the components have been cleaned and any damaged or worn components have been repaired or replaced.
- 4.7.2 Assemble one of the side plates to the rim with cap screws and lockwashers. It is not necessary to install through bolts and locknuts at this time.
- 4.7.3 Lay the rim/side plate assembly on a clean, flat work surface, side plate down.

- 4.7.4 Carefully insert the air actuating tube into the rim. Push the valves on the tube through the corresponding holes in the rim and install the spiral snap rings (if applicable).
- 4.7.5 Place a torque bar in each mating hole in the side plate, slide a friction shoe assembly onto each torque bar and carefully tap a release spring (51VC1600, 60VC1600 and 66VC1600 elements have two release springs in each cavity) into place. Make sure the spring is positioned on the side of the torque bar opposite the friction lining. Also, the spring must contact the torque bar at two points, not one. See Figure 15.

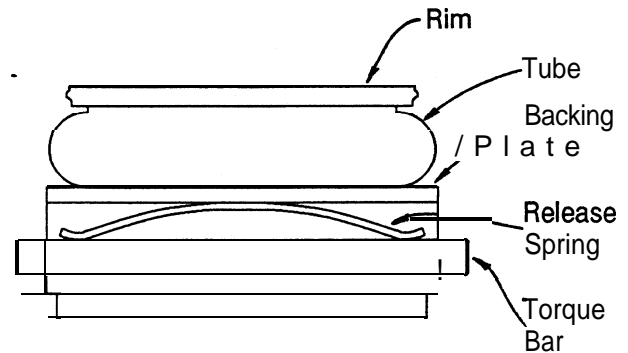

Fig. 15

- 4.7.6 Lay the remaining side plate in position so the air connections and torque bar holes are properly aligned.
- 4.7.7 Carefully guide the torque bars into the corresponding holes in the side plate. It is often helpful to install four equally spaced screws and nuts through the rim and side plate to keep some tension on the side plate throughout this step.
- 4.7.8 Attach the side plate to the rim with cap screws and lockwashers, making sure all of the torque bars are seated in their side plate holes.
- 4.7.9 Note the orientation of the air connections and install the through bolts and locknuts where applicable.
- 4.7.10 Reinstall the elbows (or quick release valves), using a good quality sealant on the pipe threads. Install the air connections on single narrow, dual narrow and single wide elements. Install only the short air connections (element closest to spider) on dual wide elements.
- 4.7.11 Reinstall per 2.0.

5.0 SPARE PARTS STORAGE

5.1 Element Assemblies

- 5.1.1 Element assemblies must always be stored flat. Storage in the standing position may cause the rims to go out-of-round.

5.2 Drums

- 5.2.1 Drums must be stored open end down. Similar to element assemblies, storage of a drum in the standing position will adversely affect roundness.

5.3 Air Actuating Tubes

- 5.3.1 Air actuating tubes are shipped from the Airflex plant folded to conserve shipping space. Upon receipt, remove the tube from its crate and allow it to assume its natural shape. Store in a cool, dry area, away from electrical equipment and ultraviolet light.

6.0 ORDERING INFORMATION/ TECHNICAL ASSISTANCE

6.1 Equipment Reference

- 6.1.1 In any correspondence regarding Air-flex equipment, refer to the information on the product nameplate. If not available, note the drum diameter, air connection configuration, mounting arrangement or any other special features and call or write:

Eaton Corporation
Airflex Division
9919 Clinton Road
Cleveland, Ohio 44144
Tel.: **(216)281-2211**
Fax: (216) 281-3890

THE PARTS LISTS ON THE FOLLOWING PAGES APPLY TO STANDARD ELEMENT ASSEMBLIES ONLY. ELEMENTS USED ON SLIP OR HIGH-TORQUE APPLICATIONS WILL HAVE DIFFERENT COMPONENT PARTS. CONSULT THE AIRFLEX FACTORY OR AN AUTHORIZED AIRFLEX DISTRIBUTOR PRIOR TO ORDERING REPLACEMENT PARTS FOR ANY ELEMENT NOT APPEARING ON THE FOLLOWING LISTS.

7.0 PARTS LISTS

7.1 Single Narrow Element Assemblies

ITEM	1		2		3		3A		4		5		6		7		10		11		12		13		
	Part No. of Complete Element	# of Air Inl.	Part No. 1 Req'd.	Part No. 1 Req'd.	Part No. 1 Req'd.	Qty.	Part No.	Qty.	Part No.	Qty.	Part No.	Qty.	Part No.	Qty.	Part No.	Qty.	Part No.	Qty.	Lining	Rivet	Part No. 2 Req'd.	Part No.	Qty.	Part No.	Qty.
11.5 VC 500	Minus Side Conn.	1 or 2	142639HA																						
	Side Connection	1	142639HU	403090	131 x 11	1		1	412178-02	1	412324-01	1	412324-01	1	414576	8 Req'd.	130 x 72	48 Req'd.	414575	8 Req'd.	412123	201372	8 Req'd.	201373	8 Req'd.
	Side Connection	2	142639HP			2				2		2	412324-01	2											
14 VC 500	Minus Side Conn.	1, 2 or 4	143829HA																						
	Side Connection	1	143829HU			92 x 6	1			1															
	Quick Release Valve	1	143829HM																						
	Side Connection	2	143829HP	406274		2				2	412178-03	2	412324-02	2	414513	8 Req'd.	130 x 72	80 Req'd.	414577		412124	307353	8 Req'd.	307354	8 Req'd.
	Quick Release Valve	2	143829HN																						
	Side Connection	4	143829HC			92 x 6	4			4															
16 VC 600	Quick Release Valve	4	143829HE							4															
	Minus Side Conn.	1, 2 or 4	142640HA																						
	Side Connection	1	142640HU			92 x 6	1			1															
	Quick Release Valve	1	142640HM																						
	Side Connection	2	142640HP	402704		2				2	412178-03	2	412324-02	2	414580	8 Req'd.	130 x 72	80 Req'd.	414579	8 Req'd.	412125	201301	8 Req'd.	301352	8 Req'd.
	Quick Release Valve	2	142640HN																						
20 VC 600	Side Connection	4	142640HC			92 x 6	4			4															
	Quick Release Valve	4	142640HE							4															
	Minus Side Conn.	1, 2 or 4	142641HA																						
	Side Connection	1	142641HU			92 x 6	1			1															
	Quick Release Valve	1	142641HM																						
	Side Connection	2	142641HP	402732		2				2	412178-03	2	412324-02	2	307359	10 Req'd.	130 x 71	100 Req'd.	307358	10 Req'd.	412126	201301	10 Req'd.	301352	10 Req'd.
24 VC 650	Quick Release Valve	2	142641HN			92 x 6	4			4															
	Side Connection	4	142641HC							4															
	Quick Release Valve	4	142641HE							4															
	Minus Side Conn.	1, 2 or 4	142642HA																						
	Side Connection	1	142642HU			92 x 7	1			1															
	Quick Release Valve	1	142642HM																						
28 VC 650	Side Connection	2	142642HP	402804		2				2	412178-05	2	412324-03	2	414582	12 Req'd.	130 x 72	120 Req'd.	414581	12 Req'd.	412127	201285	12 Req'd.	301352	12 Req'd.
	Quick Release Valve	2	142642HN																						
	Side Connection	4	142642HC			92 x 7	4			4															
	Quick Release Valve	4	142642HE							4															
	Minus Side Conn.	1, 2 or 4	142643HA																						
	Side Connection	1	142643HU			92 x 7	1			1															
30 VC 650	Quick Release Valve	1	142643HM																						
	Side Connection	2	142643HP	402893		2				2	412178-05	2	412324-03	2	414584	14 Req'd.	130 x 72	140 Req'd.	414583	14 Req'd.	412128	201285	14 Req'd.	301352	14 Req'd.
	Quick Release Valve	2	142643HN																						
	Side Connection	4	142643HC			92 x 7	4			4															
	Quick Release Valve	4	142643HE							4															
	Minus Side Conn.	1, 2 or 4	142644HA																						

ITEM	Element Description	# of Air Int.	Part No. of Complete Element	1		2		3		3A		4		5		6		7		10		11		12		13			
				Part No.	1 Req'd.	Part No.	1 Req'd.	Part No.	Qty.	Part No.	Qty.	Part No.	Qty.	Part No.	Qty.	Part No.	Qty.	Part No.	Qty.	Part No.	Qty.	Lining	Rivet	Part No.	2 Req'd.	Part No.	14 Req'd.	Part No.	16 Req'd.
28 VC 650	Minus Side Conn.	1,2 or 4	142643HA																										
	Side Connection	1	142643HU			92x7	1					87x14	1																
	Quick Release Valve	1	142643HM										72x32	1															
	Side Connection	2	142643HP	402694	402693	92x7	2						87x14	2	412178-05	2	412324-03	2	414584	14 Req'd.	414583	130x72	412128	201285	14 Req'd.	301332	14 Req'd.		
	Quick Release Valve	2	142643HN										72x32	2															
	Side Connection	4	142643HC			92x7	4						87x14	4															
33 VC 650	Quick Release Valve	4	142643HE										72x32	4															
	Minus Side Conn.	1,2 or 4	142644HA																										
	Side Connection	1	142644HU			92x8	1						87x16	1															
	Quick Release Valve	1	142644HM										72x33	1															
	Side Connection	2	142644HP	402821	402822	92x8	2						87x16	2	412178-06	2	412324-04	2	414586	16 Req'd.	414585	130x73	412129	201283	16 Req'd.	301333	16 Req'd.		
	Quick Release Valve	2	142644HN										72x33	2															
Side Connection	4	142644HC			92x8	4						87x16	4																
Quick Release Valve	4	142644HE										72x33	4																
37 VC 650	Minus Side Conn.	1,2 or 4	142645HA																										
	Side Connection	1	142645HU			92x8	1						87x16	1															
	Quick Release Valve	1	142645HM										72x33	1															
	Side Connection	2	142645HP	402671	402670	92x8	2						87x16	2	412178-06	2	412324-04	2	414586	18 Req'd.	414585	130x73	412130	201283	18 Req'd.	301333	18 Req'd.		
	Quick Release Valve	2	142645HN										72x33	2															
	Side Connection	4	142645HC			92x8	4						87x16	4															
Quick Release Valve	4	142645HE										72x33	4																
42 VC 650	Minus Side Conn.	1,2 or 4	142647HA																										
	Side Connection	1	142647HU			92x8	1						87x16	1															
	Quick Release Valve	1	142647HM										72x33	1															
	Side Connection	2	142647HP	402829	402830	92x8	2						87x16	2	412178-06	2	412324-04	2	414580	20 Req'd.	414589	130x73	412131	201283	20 Req'd.	301333	20 Req'd.		
	Quick Release Valve	2	142647HN										72x33	2															
	Side Connection	4	142647HC			92x8	4						87x16	4															
Quick Release Valve	4	142647HE										72x33	4																

7.2 Dual Narrow Element Assemblies

		ITEM			
		Complete Dual Element	Single Elements*	8	9
11.5VC500	Element with two Side Connections	142112	142639HA 2 Req'd	105808	105898
	Element with four Side Connections	142112C		105808A	105898
14VC500	Element with two Side Connections	143114	143829HA 2 Req'd	105809	105899
	Element with two Quick Release Valves	143114E		105809B	105899
	Element with four Side Connections	143114C		105809A	105899
	Element with four Quick Release Valves	143114D		105809C	105899
16VC600	Element with two Side Connections	142115	142640HA 2 Req'd	105810	105900
	Element with two Quick Release Valves	142115E		105810B	105900
	Element with four Side Connections	142115C		105810A	105900
	Element with four Quick Release Valves	142115D		105810C	105900
20VC600	Element with two Side Connections	142116	142641HA 2 Req'd	105810	105900
	Element with two Quick Release Valves	142116E		105810B	105900
	Element with four Side Connections	142116C		105810A	105900
	Element with four Quick Release Valves	142116D		105810C	105900
24VC650	Element with two Side Connections	142117	142642HA 2 Req'd	105811	105901
	Element with two Quick Release Valves	142117E		105811B	105901
	Element with four Side Connections	142117C		105811A	105901
	Element with four Quick Release Valves	142117D		105811C	105901
28VC650	Element with two Side Connections	142118	142643HA 2 Req'd	105811	105901
	Element with two Quick Release Valves	142118E		105811B	105901
	Element with four Side Connections	142118C		105811A	105901
	Element with four Quick Release Valves	142118D		105811C	105901
33VC650	Element with two Side Connections	142119	142644HA 2 Req'd	105812	105902
	Element with two Quick Release Valves	142119E		105812B	105902
	Element with four Side Connections	142119C		105812A	105902
	Element with four Quick Release Valves	142119D		105812C	105902
37VC650	Element with two Side Connections	142120	142645HA 2 Req'd	105812	105903
	Element with two Quick Release Valves	142120E		105812B	105903
	Element with four Side Connections	142120C		105812A	105903
	Element with four Quick Release Valves	142120D		105812C	105903
42VC650	Element with two Side Connections	142121	142647HA 2 Req'd	105812	105904
	Element with two Quick Release Valves	142121E		105812B	105904
	Element with four Side Connections	142121C		105812A	105904
	Element with four Quick Release Valves	142121D		105812C	105904

* The second column under "ITEM" lists the part numbers of the two single elements that make up the dual mounted element assembly. To find part numbers of components, locate the element number in the parts list for single element application. Find the part numbers in the corresponding item column.

7.3 Single Wide Element Assemblies

	Element Description	No. Of Air Inlets	Part No. Of Complete Element	ITEM												
				1	2	3	3A	4	5	6	7	10	11	12	13	
			Part No. 1 Reqd.	Part No. 1 Reqd.	Part No. Qty.	Part No. Qty.	Part No. Qty.	Part No. Qty.	Part No. Qty.	Part No. Qty.	Part No. Qty.	Part No. Qty.	Part No. Qty.	Part No. Qty.	Part No. Qty.	Part No. Qty.
14/VC 1000	Minus Side Conn.	1,2 or 4	142838HA													
	Side Connection	2	142838HP	408141-01	92x6 2			87 x 12 2	412178-03 2		412324-02 2		414592 8 Reqd.	414591 130 x 72 96 Reqd.	412124	303567 8 Reqd.
16 VC 1000	Minus Side Conn.	1,2 or 4	142821HA													
	Side Connection	1	142821HU		92x6 1			87 x 12 1								
	Quick Release Valve	1	142821HM				145406DF 1	72 x 31 1								
	Side Connection	2	142821HP	405954	92x6 2			87 x 12 2	412178-03 2		412324-02 2		414594 8 Reqd.	414593 130 x 72 80 Reqd.	412156	301831 8 Reqd.
	Quick Release Valve	2	142821HN				145406DF 2	72 x 31 2								
	Side Connection	4	142821HC		92x6 4			87 x 12 4								
20 VC 1000	Quick Release Valve	4	142821HE				145406DF 4	72 x 31 4								
	Minus Side Conn.	1,2 or 4	142832HA													
	Side Connection	1	142832HU		92x6 1			87 x 12 1								
	Quick Release Valve	1	142832HM				145406DF 1	72 x 31 1								
	Side Connection	2	142832HP	503302-01	92x6 2			87 x 12 2	412178-03 2		412324-02 2		414596 8 Reqd.	414595 130 x 72 80 Reqd.	412157	301831 8 Reqd.
	Quick Release Valve	2	142832HN				145406DF 2	72 x 31 2								
24 VC 1000	Side Connection	4	142832HC		92x6 4			87 x 12 4								
	Quick Release Valve	4	142832HE				145406DF 4	72 x 31 4								
	Minus Side Conn.	1,2 or 4	142875HA													
	Side Connection	1	142875HU		92x7 1			87 x 14 1								
	Quick Release Valve	1	142875HM				145407DF 1	72 x 32 1								
	Side Connection	2	142875HP	404688-01	92x7 2			87 x 14 2	412178-05 2		412324-03 2		414598 10 Reqd.	414597 130 x 72 100 Reqd.	412158	301831 10 Reqd.
28 VC 1000	Quick Release Valve	2	142875HN				145407DF 2	72 x 32 2								
	Side Connection	4	142875HC		92x7 4			87 x 14 4								
	Quick Release Valve	4	142875HE				145407DF 4	72 x 32 4								
	Minus Side Conn.	1,2 or 4	142874HA													
	Side Connection	1	142874HU		92x7 1			87 x 14 1								
	Quick Release Valve	1	142874HM				145407DF 1	72 x 32 1								
28 VC 1000	Side Connection	2	142874HP	405503-01	92x7 2			87 x 14 2	412178-05 2		412324-03 2		414600 10 Reqd.	414599 130 x 72 100 Reqd.	412159	301831 10 Reqd.
	Quick Release Valve	2	142874HN				145407DF 2	72 x 32 2								
	Side Connection	4	142874HC		92x7 4			87 x 14 4								
	Quick Release Valve	4	142874HE				145407DF 4	72 x 32 4								

ITEM	1		2		3		3A		4		5		6		7		10		11		12		13		
	Part No. 1 Reqd.	Part No. 1 Reqd.	Tube 1 Reqd.	Step Ring 4 Reqd.	Part No.	Qty.	Part No.	Qty.	Part No.	Qty.	Part No.	Qty.	Part No.	Qty.	Part No.	Qty.	Part No.	Qty.	Lining	Screw	Nut	Part No. 1 Reqd.	Part No.	Part No.	Part No.
32 V/C 1000	Minus Side Conn.	142673HA																							
	Side Connection	1	402330-01			92 x 7	1												414602	330 x 208	110 x 23	412160	301839	301718	
	Quick Release Valve	1																							
	Quick Release Valve	1																							
38 V/C 1200	Side Connection	1	404504	190 x 3		92 x 8	1	145407DF	1	87 x 14	1														
	Quick Release Valve	1																							
	Side Connection	2				92 x 7	2			87 x 14	2	412178-06		412324-03											
	Quick Release Valve	2																							
42 V/C 1200	Side Connection	1	403799	190 x 3		92 x 8	1	145141DF	1	87 x 16	1														
	Quick Release Valve	1																							
	Side Connection	2				92 x 8	2			87 x 16	2	412178-06		412324-04											
	Quick Release Valve	2																							
46 V/C 1200	Side Connection	1	403800-01	190 x 3		92 x 8	1	145141DF	1	87 x 16	1														
	Quick Release Valve	1																							
	Side Connection	2				92 x 8	2			87 x 16	2	412178-06		412324-04											
	Quick Release Valve	2																							
52 V/C 1200	Side Connection	1	404602	190 x 3		92 x 8	1	145141DF	1	87 x 16	1														
	Quick Release Valve	1																							
	Side Connection	2				92 x 8	2			87 x 16	2	412178-07		412324-04											
	Quick Release Valve	2																							
51 V/C 1600	Side Connection	1	503985	190 x 83		92 x 10	1	145413BD	1	87 x 20	1														
	Quick Release Valve	1																							
	Side Connection	2				92 x 10	2			87 x 20	2	412178-08		412324-05											
	Quick Release Valve	2																							
60 V/C 1600	Side Connection	1	506674	190 x 83		92 x 10	1	145413BD	1	87 x 20	1														
	Quick Release Valve	1																							
	Side Connection	2				92 x 10	2			87 x 20	2	412178-09		412324-05											
	Quick Release Valve	2																							
66V/C 1600	Side Connection	1	511350	190 x 15		92 x 10	1	145413BD	1	87 x 20	1														
	Quick Release Valve	1																							
	Side Connection	2				92 x 10	2			87 x 20	2	412178-04		412324-06											
	Quick Release Valve	2																							

7.4 Dual Wide Element Assemblies

	ITEM			
	Complete Dual Element With Four Side Connections	Single Elements*	8	9
16VC1000	142122C	142821HA 2 Req'd	105815A	105905
20VC1000	142123C	142832HA 2 Req'd	105815A	105905
24VC1000	142124C	142675HA 2 Req'd	105816A	105901
28VC1000	142125C	142674HA 2 Req'd	105816A	105901
32VC1000	142126C	142673HA 2 Req'd	105816A	105906
38VC1200	142127C	142739HA 2 Req'd	105817A	105907
42VC1200	142128C	142677HA 2 Req'd	105817A	105908
46VC1200	142129C	142671HA 2 Req'd	105891A	105909
52VC1200	142131C	142841HA 2 Req'd	105893A	105910
51VC1600	142130C	142835HA 2 Req'd	105892A	105910
60VC1600	142132AL	142915MB 2 Req'd	105894A	105911
66VC1600	142198C	142097HA 2 Req'd	105897A	----

* The second column under "ITEM" lists the part numbers of the two single elements that make up the dual mounted element assembly. To find part numbers of the components, locate the element number in the parts list for single element application. Find the part numbers in the corresponding item column.

All elements are dual drilled.

8.0 REPAIR KITS

8.1 Friction Block and Rivet Kits

ELEMENT SIZE	NARROW SERIES			ELEMENT SIZE	WIDE SERIES		
	KIT NUMBER	QTY. FRICTION BLOCKS	QTY.** RIVETS		KIT NUMBER	QTY. FRICTION BLOCKS	QTY.** RIVETS
11.5VC500	146236AA	8	54	14VC1000	146237AA	16	102
14VC500	146236AB	8	90	16VC1000	146237AB	8	90
16VC600	146236AC	8	90	20VC1000	146237AC	8	90
20VC600	146236AD	10	110	24VC1000	146237AD	10	110
24VC650	146236AE	12	130	28VC1000	146237AE	10	110
28VC650	146236AF	14	150	32VC1000	146237AF	12	130*
33VC650	146236AG	16	170	38VC1200	146237AG	12	130*
35VC650	146236AH	18	190	42VC1200	146237AH	14	150*
37VC650	146236AJ	18	190	46VC1200	146237AJ	32	198*
42VC650	146236AK	20	210	52VC1200	146237AK	36	222*
* Fasteners for these sizes are screws and nuts - all other sizes use rivets. ** Extra fasteners supplied with each kit.				51VC1600	146237AL	36	222*
				60VC1600	146237AM	40	246*
				66VC1600	146237AN	44	246*

8.2 Friction Shoe Assembly, Torque Bar and Release Spring Kits

ELEMENT SIZE	NARROW SERIES				ELEMENT SIZE	WIDE SERIES			
	KIT NUMBER	QTY. FRICTION SHOES	QTY. TORQUE BARS	QTY. SPRINGS		KIT NUMBER	QTY. FRICTION SHOES	QTY. TORQUE BARS	QTY. SPRINGS
11.5VC500	146236A	8	8	8	14VC1000	146237A	8	8	8
14VC500	146236B	8	8	8	16VC1000	146237B	8	8	8
16VC600	146236C	8	8	8	20VC1000	146237C	8	8	8
20VC600	146236D	10	10	10	24VC1000	146237D	10	10	10
24VC650	146236E	12	12	12	28VC1000	146237E	10	10	10
28VC650	146236F	14	14	14	32VC1000	146237F	12	12	12
33VC650	146236G	16	16	16	38VC1200	146237G	12	12	12
35VC650	146236H	18	18	18	42VC1200	146237H	14	14	14
37VC650	146236J	18	18	18	46VC1200	146237J	16	16	16
42VC650	146236K	20	20	20	52VC1200	146237K	18	18	18
					51VC1600	146237L	18	18	36
					60VC1600	146237M	20	20	40
					66VC1600	146237N	22	22	44

EATON PRODUCT WARRANTY

Subject to the conditions stated herein, Eaton Corporation warrants to the Purchaser that each new Airflex Product manufactured by Eaton will be free from failures caused by defects in material and workmanship, and will deliver its rated capacity, for a period of twelve (12) months from the date of shipment to Purchaser, provided such Product is properly installed, properly maintained, operated under normal conditions and with competent supervision. Warranty claims shall be made in writing and the part or parts shall, if requested by Airflex Division, be returned prepaid to the Airflex Division for inspection. Upon a determination that a defect exists, Eaton shall thereupon correct any defect, at its option either by repairing any defective part or parts or by making available at Eaton's plant a repaired or replacement part. This warranty does not extend to normal wear parts or components of the Product, such as friction material and friction surfaces.

LIMITATION OF WARRANTY

THE FOREGOING WARRANTY IS EXCLUSIVE AND IN LIEU OF ALL OTHER WARRANTIES WHETHER WRITTEN, ORAL OR IMPLIED. ANY IMPLIED WARRANTY OF MERCHANTABILITY OR FITNESS FOR A PARTICULAR PURPOSE ARE SPECIFICALLY EXCLUDED.

In no event shall Eaton be liable for special, incidental or consequential damages. Eaton's liability arising out of the supplying of such Product, or its use, whether in warranty, contract or otherwise, shall in no case exceed the cost of correcting defects in the Products as herein provided. Upon expiration of the twelve (12) month period, all such liability shall terminate. THE FOREGOING SHALL CONSTITUTE THE SOLE REMEDY OF PURCHASER AND THE SOLE LIABILITY OF EATON.