

WCB 11060



Warning:

Forward this manual to the person responsible for Installation, Operation and Maintenance of the product described herein. Without access to this information, faulty Installation, Operation or Maintenance may result in personal injury or equipment damage.

Installation, Operation and Maintenance of Airflex® WCB Water Cooled Tensioners with Corrosion Resistant Components



Caution:

Use Only Genuine Airflex Replacement Parts

The Airflex Division of Eaton Corporation recommends the use of genuine Airflex replacement parts. The use of non-genuine Airflex replacement parts could result in substandard product performance, and may void your Eaton warranty. For optimum performance, contact Airflex:

In the U.S.A. and Canada: **(800) 233-5890**

Outside the U.S.A. and Canada: **(216) 281-2211**

June, 1998

204124

© Copyright Eaton Corp., 1998. All rights reserved.

Authorized Distributor



26255 Groesbeck Hwy.
Warren, MI 48089 U.S.A.
586.775.3000 • 586.775.3040 (Fax)
sales@midwestbrake.com
www.midwestbrake.com

Eaton® Airflex® Clutches & Brakes



Table of Contents

1.0	INTRODUCTION	7
1.1	Description	7
1.2	How it Works	7
2.0	INSTALLATION	8
2.1	Preparation	8
2.2	Alignment	8
2.3	Mounting	9
2.4	Air System	10
2.5	Coolant System	10
3.0	OPERATION	12
3.1	Conditions of Operation	12
3.2	Pressure and Speed Limits	13
3.3	Periodic Maintenance	13
4.0	MAINTENANCE	13
4.1	Wear Adjustment	14
4.2	Removal of the WCB	15
4.3	Dis-assembly of the WCB	16
4.4	Friction Lining Replacement	16
4.5	Wear Plate Replacement	17
4.6	Cylinder Seal Replacement	19
4.7	Bushing Replacement	20
4.8	Assembly of the WCB	21
4.9	Corrosion Protection	21
5.0	ORDERING INFORMATION/TECHNICAL ASSISTANCE	21
6.0	WEAR LIMITS	22
7.0	PARTS	23
8.0	REVISIONS	30

WCB Single Disc

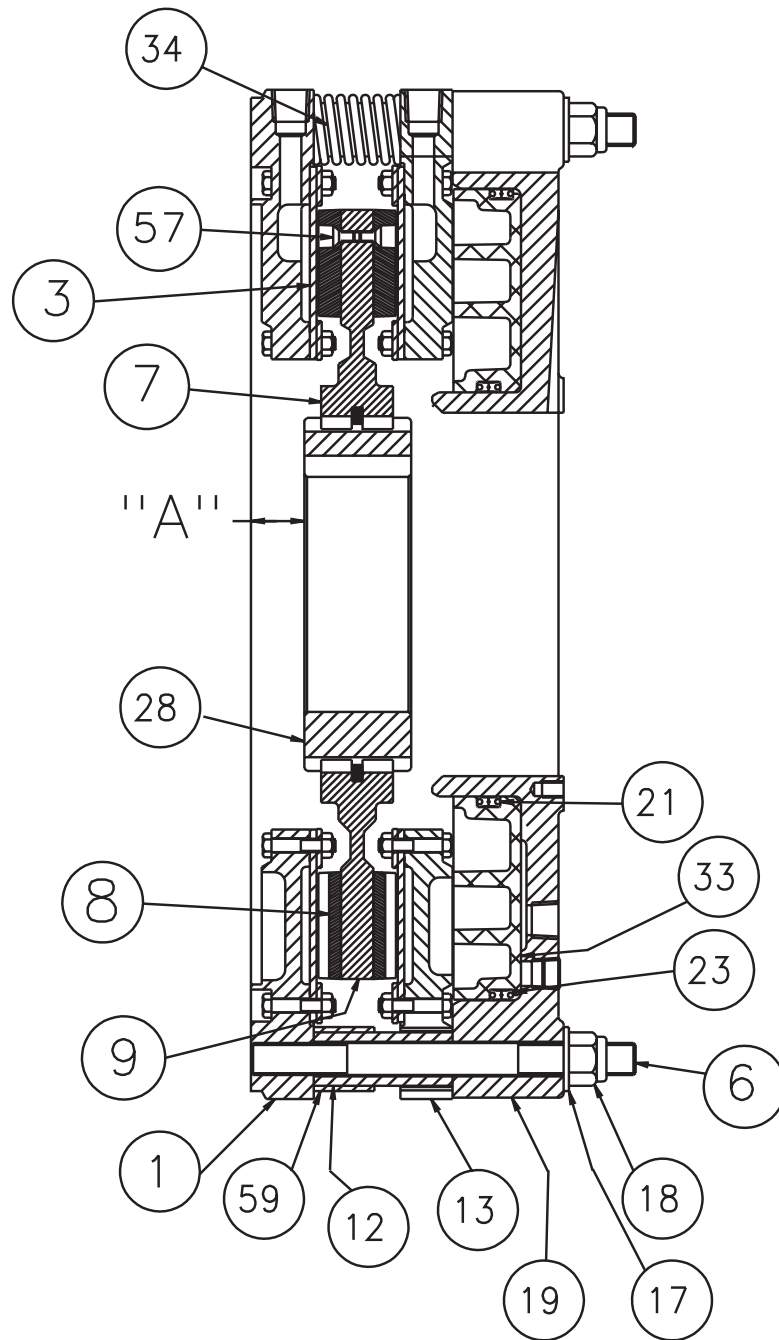

Figure 1

WCB Dual Disc

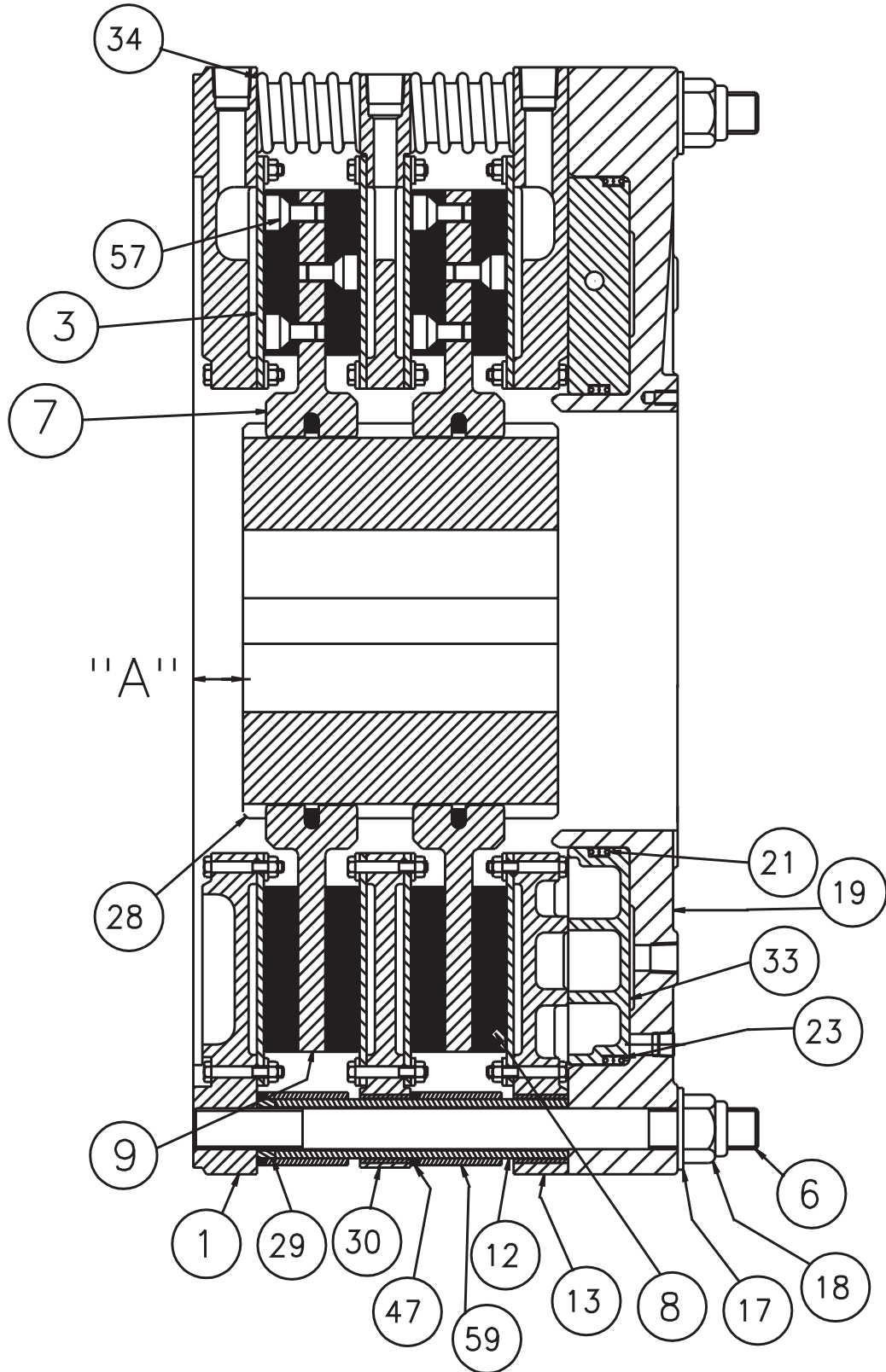
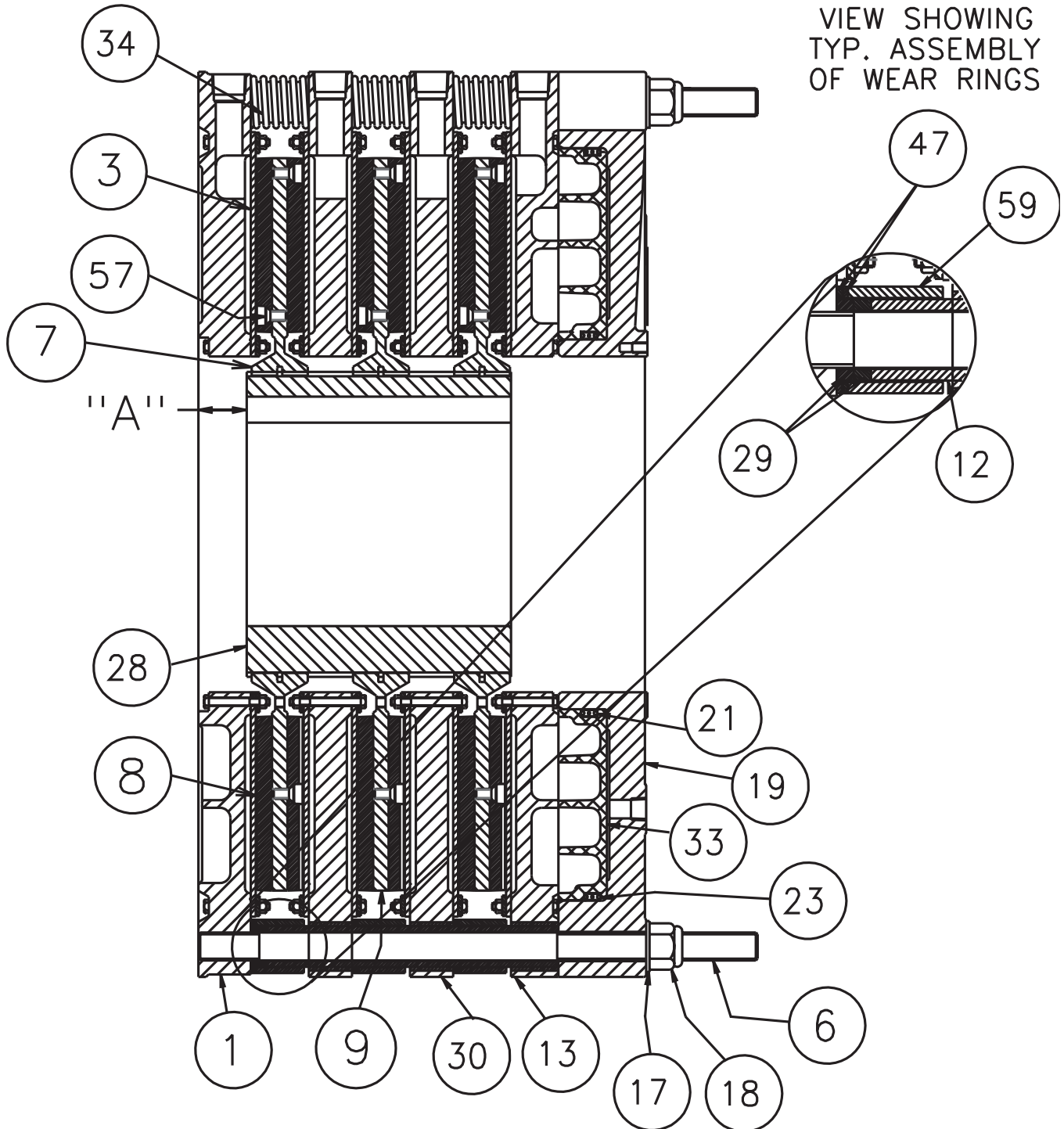
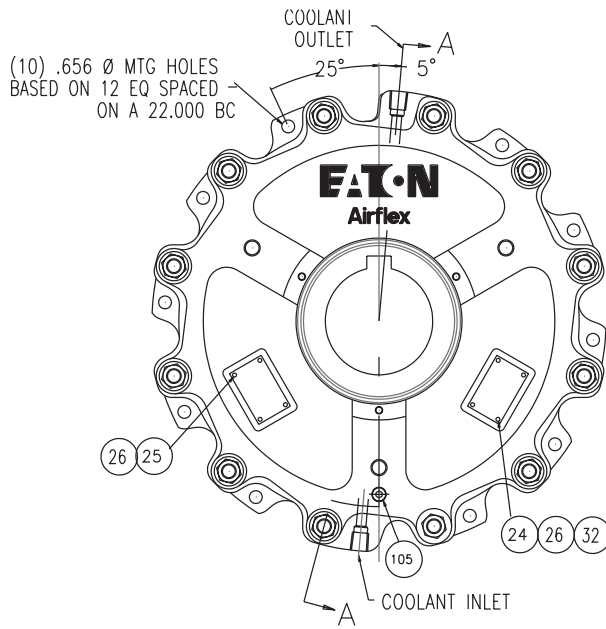

Figure 2

WCB Triple Disc





18 WCB

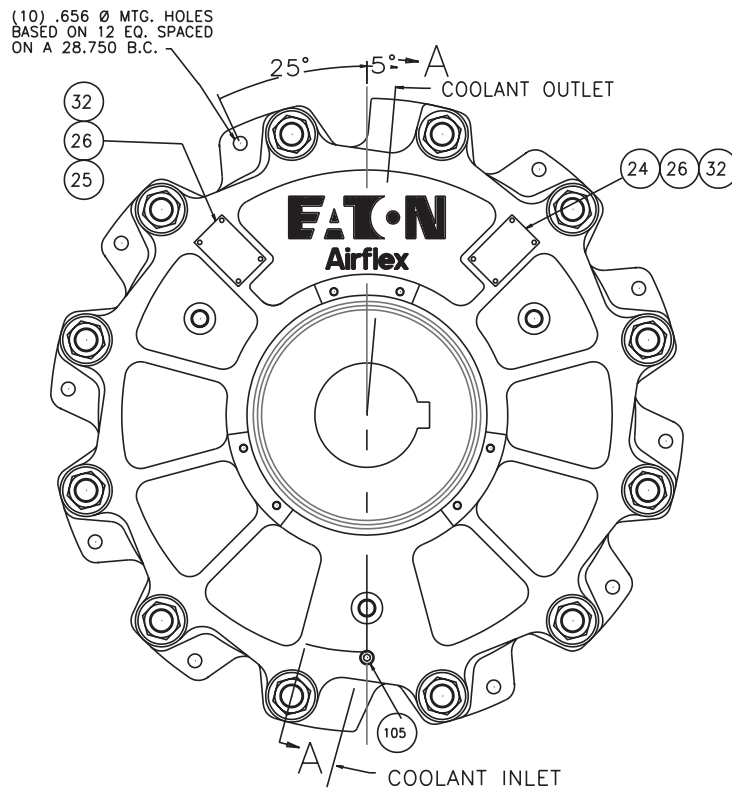

24 WCB

NOTE: The coolant outlets should be positioned at the 12 o'clock position.

Figure 4

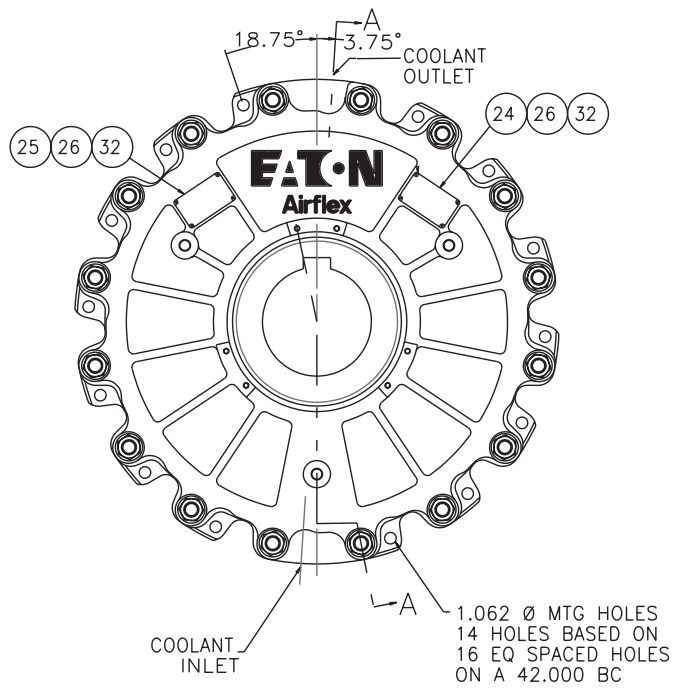

36 WCB

NOTE: The coolant outlets should be positioned at the 12 o'clock position.

Figure 5

Table 1			
Item	Description	Item	Description
1	Mounting Flange Sub-assembly	24	Warning Decal
3	Wear Plate	25	Name Plate
6	Stud	26	Screw
7	Friction Disc Sub-assembly	28	Gear
8	Friction Disc	29	Wear Spacer
9	Friction Disc Core	30	Reaction Plate Sub-assembly
12	Clamp Tube	32	Decal Plate
13	Pressure Plate Sub-assembly	33	Piston
17	Flat Washer	34	Release Spring
18	Locknut	47	Wear Ring
19	Cylinder	57	Flat Head Screw
21	Polypak Seal	59	Stop Tube

Table 2		
Tensioner Mounting Register Diameters - In. (mm)		
Size	Female Register	Male Register
18WCB	18.250/18.253 (463.5/463.6)	23.250/23.247 (590.5/590.4)
24WCB	24.375/24.378 (619.1/619.2)	29.998/29.995 (761.9/761.8)
36WCB	18.375/18.378 (466.7/466.8)	44.498/44.493 (1130.2/1130.1)

Registers to be .125"-.188"(3.2-4.8mm) deep.

1.0 INTRODUCTION

Throughout this manual there are a number of **HAZARD WARNINGS** that must be read and adhered to in order to prevent possible personal injury and/or damage to the equipment. Three signal words "**DANGER**", "**WARNING**", and "**CAUTION**" are used to indicate the severity of the hazard, and are preceded by the safety alert symbol .



Danger:

Denotes the most serious injury hazard, and is used when serious injury or death WILL result from misuse or failure to follow specific instructions.





Warning:

Used when serious injury or death MAY result from misuse or failure to follow specific instructions.



Caution:

Used when injury or product/equipment damage may result from misuse or failure to follow specific instructions.

It is the responsibility and the duty of all personnel involved in the installation, operation and maintenance of the equipment on which this device is used to fully understand the  **Danger:**,  **Warning:** and  **Caution:** procedures by which hazards are to be avoided.

1.1 Description

- 1.1.1 The Airflex WCB water-cooled tensioner is designed for constant tension applications. It is exceptionally well suited for high inertia stopping and rapid heat dissipation. The design of the WCB tensioner permits midshaft or endshaft mounting. The rugged construction ensures long, trouble free service. Several models are available having single and multiple friction discs. The tensioner model number identifies the number of discs and the disc diameter. For example, 124WCB means one 24" diameter disc. When size, such as 24WCB, is referred to in this manual, it means that the information given applies to all models using the 24" diameter disc; i.e., 124WCB, 224WCB, etc.
- 1.1.2 This manual covers WCB models with "J" (146XXXJ) designator that have Corrosion Resistant Pistons and Standard screwed on friction linings (8) and WCB models with "K" (146XXXK) designators that have Corrosion Resistant Pistons and High Coefficient screwed on friction linings.
- 1.1.3 Tensioners can be used for either closed loop or open loop water systems.
- 1.1.4 This manual includes metric equivalent usually shown in (#) following the U.S. measurement system value. Be sure to use the correct value.

1.2 How It Works

- 1.2.1 Refer to Figure 1. Air is introduced to the unit causing the pressure plate assembly (13) to move and make contact with the friction discs (8). Torque is transmitted through the studs (6) to the mounting flange (2). The release springs (34) assist in disengagement and retraction of the piston (33) and pressure plate. High heat dissipation is accomplished by passing water through a special cavity behind copper wear plates (3).

2.0 INSTALLATION



Warning:

Only qualified maintenance personnel should install, adjust or repair these units. Faulty workmanship will result in unreasonable exposure to hazardous conditions or personal injury.



Caution:

Read these instructions thoroughly and review until you fully understand the installation sequence before proceeding with the work described in this section. Failure to follow these instructions will result in unreasonable exposure to hazardous conditions or personal injury.



Caution:

Do not paint the clamp tubes (12) or the springs (34), as this may hinder the engagement or disengagement of the tensioner.



Caution:

Maximum ambient temperature is 110°F (43°C). Minimum ambient temperature for closed loop systems using ethylene glycol antifreeze is 0°F (-18°C). For open loop systems using water, the minimum temperature is 45°F (7°C).

Note: Some three and four disc units may require support on the cylinder end of the tensioner in certain high torque applications. Contact the factory for specific application information.

2.1 Preparation

- 2.1.1 Table 3 shows the relationship between the tensioner mounting surface and the end of the gear (dimension "A" on Figure 1-3). The gear is bored and keyed for a resulting Class FN2S interference fit for inch shafting and ISO System S7h6 for metric shafting.

Size	Single	Dual	Triple	Quad
18WCB	1.25 (31.8)	1.25 (31.8)	0.75 (19.1)	N/A
24WCB	1.38 (35.1)	1.00 (25.4)	0.63 (16.0)	1.38 (35.1)
36WCB	1.50 (38.1)	2.38 (60.5)	2.38 (60.5)	2.38 (60.5)

Size	Concentricity of Shaft and Brake In. (mm)	Perpendicularity of Mounting Flange (2) to Shaft - In. (mm)
18WCB	0.010 (0.25)	0.010 (0.25)
24WCB	0.010 (0.25)	0.012 (0.30)
36WCB	0.010 (0.25)	0.019 (0.48)

- 2.1.2 Figure 4 & 5 and Table 2 show the mounting dimensions for the tensioner to the machine frame or reaction bracket. Note that a male or female register may be used.

2.2 Alignment

- 2.2.1 For proper operation and service life, the tensioner reaction member must be aligned to the shaft within the limits shown on Table 4.



Caution:

Proper alignment is necessary to ensure that the friction discs track properly. Improper alignment will result in excessive wear to the friction material and its mating surfaces, the gear and splined bore of the friction disc assembly. See Figure 6.

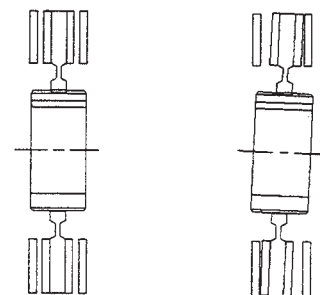

Correct Track

Incorrect Track

Figure 6

2.3 Mounting

2.3.1 The WCB must be mounted to a clean, rigid surface with hardened flat washers and screws of the grade, quantity, and size and torqued to the values identified in Table 5 for each WCB size. Mounting to a rigid surface minimizes any deflection during operation and ensures that the friction discs will track properly on the copper wear plates.



Danger:

Use only the proper number and grade fasteners shown in Table 5. Use of commercial grade (Grade 2) fasteners where Grade 8 fasteners are specified may result in failure of the fasteners and a sudden and drastic reduction in brake torque.



Caution:

Make sure that the water inlets and outlets are at the 6 o'clock and 12 o'clock positions, respectively. See Figure 4 & 5. This will ensure that there will be no air pockets in the water cavity during operation, which would allow the tensioner to over-heat.

2.3.2 To facilitate the tensioner mounting process, the friction disc assemblies should be aligned to the gear and centered in the tensioner. With the tensioner laying on the floor, lower the gear (28) slowly and very carefully into the splined bore of the friction disc assemblies (7). Adjust the discs so that they are centered in the tensioner and fit the gear. Apply and maintain an air pressure of 25 PSIG (1.7 bar) to the cylinder. This will engage and hold the discs in position to facilitate tensioner installation. Remove the gear.

2.3.3 Ensure that the shaft is free of nicks or burrs and the key fits properly in the shaft and gear.

2.3.4 Apply a light coat of anti-seizing compound to the shaft and key. Tap the key into the shaft keyway.

2.3.5 Press the gear onto the shaft, making sure that the dimension between the gear and the tensioner mounting surface ("A") is maintained. See Figure 1- 3 and Table 3. Heating the gear uniformly to 250°F (121°C) will expand the bore and ease assembly.



Caution:

For an Airflex supplied plated gear, do not heat the gear to more than 300° F (150°C). Temperatures in excess of 300°F (150°C) will cause the plating to separate from the gear.

2.3.6 Apply a thin coat of Molub-alloy® 412ES to the gear teeth.

2.3.7 Using lifting equipment and straps, lift the tensioner and slide it over the gear. Fasten it to the mounting surface using the hardware called for in Table 5.

2.3.8 Torque the screws to the values called for in Table 5 using a crosswise tightening sequence. Release the air pressure applied in 2.3.2

Fastener		18WCB	24WCB	36WCB
Item #18	Description	3/4-10NC-3	1 1/8-7NC Gr. 8	1 3/8-6NC Gr. 8
	Torque	150 (203)	500 (677)	750 (1016)
Item # 5	Description	5/16-18NC	5/16-18NC	3/8-16NC2
	Torque	25(31)	25(31)	40(54)
Mounting Screw	Description	5/8-11NC-2 Gr. 8	5/8-11NC-2 Gr. 8	1-8NC2 Gr. 8
	Quantity	10	10	14
	Torque	150 (203)	150 (203)	660 (895)

2.4 Air System



Warning:

Maximum allowable air pressure is 150 PSIG (10.3 bar). Application of pressure exceeding maximum allowable may result in damage to the tensioner.

- 2.4.1 All pipes should be free of metal chips, cutting compound and any other foreign matter. Pipe ends should be reamed after cutting to eliminate possible restrictions. A minimum of bends and elbows should be used.
- 2.4.2 Air inlets for the WCB are on the face of the cylinder (19). See table 6. Use only clean, filtered air (a 50 micron filter or better is recommended) which is free of excess moisture.

2.5 Coolant System



Warning:

Maximum allowable water pressure is 40 PSIG (2.7 bar). Application of pressure exceeding maximum allowable may result in damage to the tensioner.

- 2.5.1 Coolant supply connections to the tensioner should provide a parallel flow through each section of the tensioner. Series flow is not generally recommended, contact Airflex for specific applications. Inlet and outlet coolant manifolds must be provided with flexible connecting hose to each tensioner coolant section. Coolant supply connection to the tensioner must be flexible to allow axial travel of the pressure plate and reaction plate during tensioner operation. Coolant and coolant supply lines should be free of foreign material (a 500 micron water filter is recommended). Reductions in the recommended line diameter should be avoided. Avoid loops and bends in the lines which may create air pockets, which substantially reduce the flow of coolant. Figure 7 illustrates a typical closed loop liquid to liquid coolant system. The heat exchanger and temperature control would be replaced with a radiator, fan and motor in a liquid to air system.

Model	Thread Size
18 WCB	1/2-14 NPT
24 WCB	1/2-14 NPT
36 WCB	3/4-14 NPT

- 2.5.2 Figure 7 shows the flow control valve settings for each type of element depending on the number of friction surfaces to be cooled.



Caution:

Make sure that the water inlets and outlets are at the 6 o'clock and 12 o'clock positions, respectively. This will ensure that there will be no air pockets in the water cavity during operation, which would allow the tensioner to overheat.

- 2.5.3 The coolant supply and discharge pipe sizes, along with minimum flow rates for the tensioner rated horsepower, are given in Table 7.
- 2.5.4 Each coolant cavity of each WCB tensioner has been statically tested at the factory before shipment. If leakage is suspected, a static or dynamic test may be made as follows:

Static Pressure Test:

First, bleed all air from within the coolant cavity. Air bleeding must be accomplished by running coolant through the cavity with the tensioner secured in its operating position. After the air has been removed, install a pipe plug in the outlet and apply 40 PSIG (2.7 bar) coolant pressure measured at the inlet to the water cavity. Maintain this pressure for 30 minutes. Check for leakage at O.D. and I.D. seal areas.



Caution:

Do not apply air pressure to the cylinder of the tensioner during static coolant pressure testing. Surge pressures exceeding 40 PSIG (2.7 bar) could be developed within the coolant cavities which will cause damage to the seals.

Table 7
Coolant Supply Data

Size	Thermal Rating ¹ HP (kW)	Water Inlet and Outlet Pipe Size	Min. Flow Rate ³ GPM (dm3/min) Sea Water	Min. Flow Rate ² GPM (dm3/min) 100% Water	Min. Flow Rate ² GPM (dm3/min) 70% Water, 30% Ethylene Glycol by Vol.	Min. Flow Rate ² GPM (dm3/min) 60% Water, 40% Ethylene Glycol by Vol.	Min. Flow Rate ² GPM (dm3/min) 50% Water, 50% Ethylene Glycol by Vol.
118WCB	120 (89.4)	1/2-14NPT	14.5(54.5)	12 (45.4)	14 (53.6)	15.6 (58.8)	18 (67.9)
218WCB	240 (179)	1/2-14NPT	29 (109)	24 (91)	28 (106)	31(117)	36 (136)
318WCB	360 (268)	1/2-14NPT	43 (163)	36 (136)	42 (162)	47 (177)	54 (204)
124WCB	270 (201)	3/4-14 NPT	32.5(122.5)	27 (102)	32 (121)	35 (132)	40 (151)
224WCB	540 (402)	3/4-14 NPT	65(245)	54 (204)	64 (242)	70 (265)	80 (303)
324WCB	810 (603)	3/4-14 NPT	97 (365)	81(305)	96 (361)	105 (395)	120 (451)
424WCB	1080 (805)	3/4-14 NPT	130 (489)	108 (406)	128 (481)	140 (526)	160 (602)
136WCB	650 (485)	1 1/4-11 NPT	78(293)	65 (246)	76 (288)	84 (318)	98 (371)
236WCB	1300 (969)	1 1/4-11 NPT	156 (587)	130 (489)	152 (572)	168 (632)	196 (737)
336WCB	1950 (1454)	1 1/4-11 NPT	234 (880)	195 (738)	228 (863)	253 (958)	294 (1113)
436WCB	2600 (1937)	1 1/4-11 NPT	312 (1173)	260 (978)	304 (1143)	336 (1263)	392 (1474)

1 - Thermal rating based on a 70°F (21°C) water inlet temperature and a 50°F (28°C) temperature rise between inlet and outlet.

2 - Flow rate is based on requirement of 1 U.S. GPM per 10 HP (1.97 kW perdm3/min) thermal dissipation.

3 - Flow rate when using Sea water is based on requirement of 1 U.S. GPM per 8 HP (1.58 kW per dm3/min) thermal dissipation. If sea water is used as a coolant, a 500 micron filter is recommended. After use, coolant cavities must be flushed with fresh (un-contaminated) water.

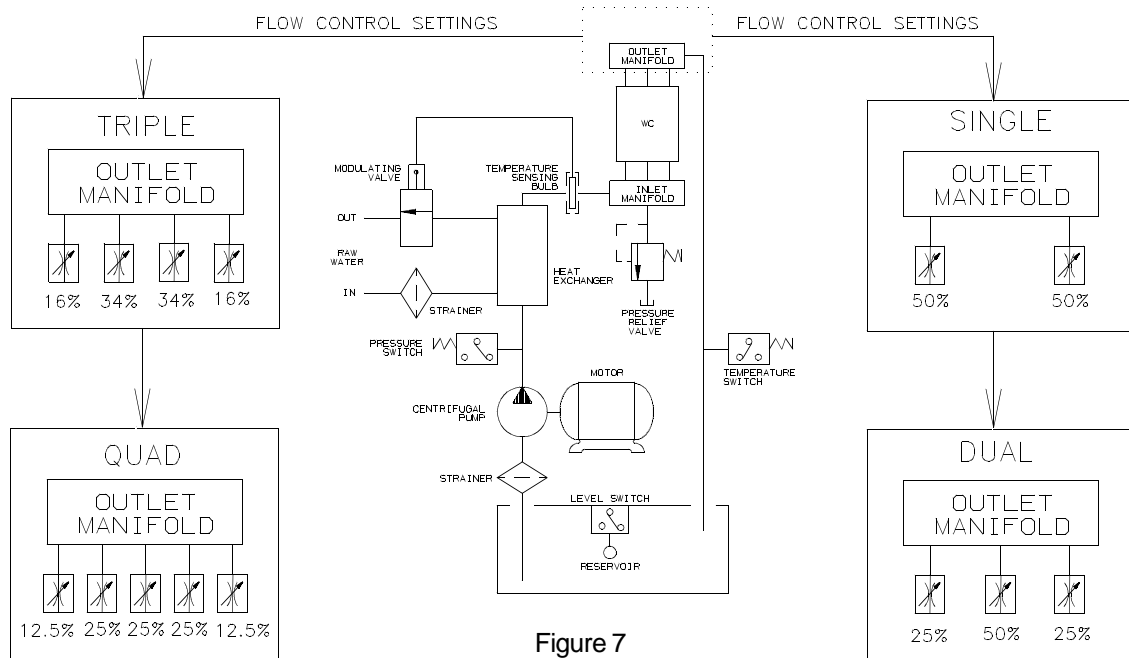

Figure 7

Dynamic Flow Test:

Dynamic flow testing of the tensioner should be conducted at the required flow rate for the rated HP dissipation and coolant quality, as given in Table 7. Inlet pressure is not to exceed 40 PSIG (2.7 bar).

There should be no restrictions on the outlet side of the brake to cause any back pressure to the unit. Coolant inlet and hose size should be as given in Table 7. Check for leakage at the O.D. and I.D. seal areas.

- 2.5.5 The coolant supply temperature at the inlet should be 100°F (38°C) or lower. The coolant outlet temperature should not exceed the values given in Table 8. However, in no event should there be more than a 50°F (28°C) temperature rise between inlet and outlet. See Table 8 for maximum allowable outlet coolant temperature with a water/ethylene glycol mix.

2.5.6 Open Loop Systems

For efficient operation of the WCB, an adequate supply of filtered fresh water is required. (See 2.5.1-2.5.2). Excessive water hardness promotes the formation of scale deposits, which, in time, will affect the service life of the WCB unit. Water of high acidity may cause electrolytic corrosion between the dissimilar metals used in the WCB. Water treatment should be considered if the properties of the water exceed the following:

Equivalent calcium carbonate content (hardness): Maximum 100 p.p.m.

pH value: 7.0 to 9.0.

2.5.7 Closed Loop Systems

For efficient operation of the WCB in a closed loop system, ethylene glycol coolant conforming to SAE Standard J1034 should be used. For preparation of the proper concentration of a water/ethylene glycol mixture, use makeup water which is low in corrosive ions such as chlorides and sulfates.

pH value of the water/ethylene glycol mixture: 7.5. to 10.5.

Water/Ethylene Glycol Mixture % by Volume	Maximum Outlet Coolant Temperature °F (°C)
100/0	150 (66)
70/30	165 (74)
60/40	165 (74)
50/50	170 (77)

3.0 OPERATION

3.1 Conditions of Operation

The following Hazard Warnings are to be followed for proper WCB functioning:



Warning:

The maximum recommended operating air pressure is 150 PSIG (10.3 bar). Air pressure in excess of 150 PSIG (10.3 bar) will cause high stress in various parts of the tensioner. Do not risk personal injury or damage to the equipment!



Warning:

Protective means must be used to prevent rain, water, oil, grease, dirt or coolant from coming into contact with the surfaces of the friction discs (8) or the wear plates (3). Oil or grease on these parts will significantly reduce the torque capacity of the unit. Dirt or coolant will produce erratic torque. Do not risk personal injury or damage to the equipment!



Warning:

The friction disc assembly (7) maximum disc speed must not exceed the speeds listed in Table 9. Exposure to speeds in excess of these values may cause the friction discs to burst and result in extensive damage to the tensioner and/or cause personal injury.



Caution:

For proper cooling of the WCB tensioner, it is required that the coolant inlet be located at the 6 o'clock position and the outlet be located at the 12 o'clock position. This will assure that all coolant cavities are filled and will prevent overheating. Refer to Figure 4 & 5.



Caution:

For operation in subfreezing temperatures, ethylene glycol antifreeze must be added to the water. The antifreeze content of the mixture is critical and should not exceed 50% by volume since excessive amounts will reduce cooling capacity and can cause coolant leakage due to overheating. Refer to Section 2.5 and Table 7.

3.2 Pressure and Speed Limits

- 3.2.1 Maximum applied air pressure is 150 PSIG (10.3 bar). Maximum water pressure measured at the inlet of the tensioner is 45 PSIG (3.1 bar).
- 3.2.2 Maximum slip speeds and (free wheeling) disc speeds are shown in Table 9.



Caution:

Excessive slip speeds will result in rapid friction material wear. For good life, the values in Table 9 should not be exceeded.



Caution:

A minimum wear in period of four hours at 50% of the rated horsepower is recommended for the friction couple to achieve rated torque.

Table 9 Maximum Disc Speeds		
Size	Max. Slip Speed RPM	Max. Disc Speed RPM
18WCB	955	1600
24WCB	715	1200
36WCB	475	700

3.3 Periodic Maintenance

- 3.3.1 Periodically check for air leakage in the area of the cylinder seals (21,23). For replacement, refer to Section 4.0 MAINTENANCE.
- 3.3.2 Periodically observe the friction disc assembly(s) with the brake released. Dragging friction discs may be caused by wear or contamination at the gear-friction disc core contact areas or misalignment.
- 3.3.3 Pneumatic and electrical control interlocks should be periodically checked for correct settings and operation.
- 3.3.4 Periodically remove the brass plug (105) or lowest air line from the cylinder and drain any accumulated water.

4.0 MAINTENANCE



Warning:

Before doing any maintenance work on the WCB unit, make sure that the machinery will remain in a safe position. Failure to do so could result in serious injury or possibly death.



Warning:

Only qualified maintenance personnel should install, adjust or repair these WCB units. Faulty workmanship will result in unreasonable exposure to hazardous conditions or personal injury.

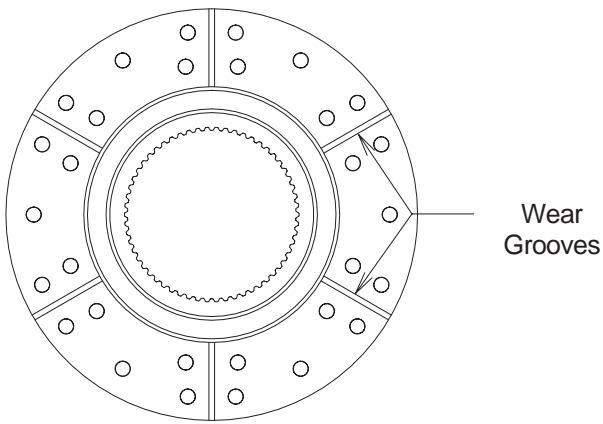

Figure 8

! Caution:

Read these instructions thoroughly and review until you fully understand the parts replacement steps before proceeding with the work described in this section. Failure to follow these instructions can result in unreasonable exposure to hazardous conditions or personal injury.

4.1 Wear Adjustment

4.1.1 Single disc WCB's

Note: Item numbers (#) are shown on Figure 1.

4.1.1.1 There is no adjustment for single disc elements. When the pressure plate (13) bottoms against the stop tubes (59), replace friction material and inspect wear plates for wear. See section 6.0.

4.1.2 Dual, Triple & Quad disc WCB's

Note: Items (#) referenced in Figures 2 & 3.

4.1.2.1 Dual disc elements have one adjustment, triple disc elements have two adjustments and quad disc elements have three adjustments. Follow the wear spacer adjustment procedures in section 4.1.3 for each adjustment made.

4.1.3 Wear adjustment procedures (Multi disc)

Note: Item numbers (#) are shown on Figures 2, 3 and 4.

Model	Nut Size	Socket Depth
118	1 1/16"	1 3/4"
218		2 3/8"
318		2 1/4"
124	1 5/8"	1 3/4"
224		2 1/4"
324		6 5/8"
424		7 1/8"
136	2"	3 1/4"
236		4"
336		5 1/2"
436		6 1/5"

Note: On all units, the friction material must be replaced when worn to the bottom of the groove on the friction lining. See Figure 8. See Table 17 in Section 6.0 for new wear groove depth.

- 4.1.3.1 Disconnect air and water supply lines from the tensioner.
- 4.1.3.2 While supporting the cylinder (19), loosen the locknuts (18) ONE TURN AT TIME and in an alternating (crosswise) pattern until the spring force is completely relieved. Remove the locknuts and washers (17). Mark all of the water outlet ports for identification. Deep well sockets are required. See table 10 for size and depth of socket required.
- 4.1.3.3 Using lifting equipment, carefully remove the cylinder (19) and piston (33) as an assembly. Set aside in a clean area. (Piston side up.)

Note: If a stud (6) should happen to come loose, remove it completely, clean the threads on the stud and the threads in the mounting flange. Apply Loctite® Primer Grade "T" to the stud threads. After the threads have dried, assemble to the mounting flange using Loctite® #262. The end of the stud must not extend past the mounting surface of the mounting flange.

! Caution:

Loctite® #262 must be shaken prior to application.

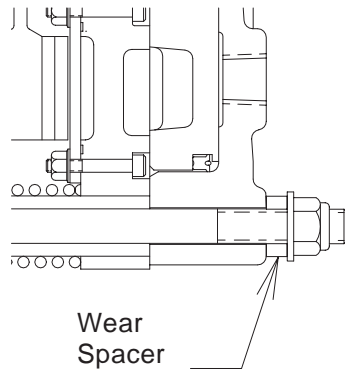

Figure 9



Caution:

Loctite® #262 may irritate sensitive skin. Refer to the product label for proper safety precautions.

- 4.1.3.4 Using lifting equipment, remove the pressure plate assembly (13) and carefully place it on a suitable work surface with the wear plate (3) facing up. Do not damage the wear plate.
- 4.1.3.5 Remove the friction disc assembly, the reaction plate assembly (30), release springs (34), stop tubes (59) and wear ring (47) from each stud and set aside Repeat for three and four disc units.
- 4.1.3.6 Remove the clamp tubes (12) and one wear spacer (29) from each stud. Reinstall the clamp tubes, set aside the removed wear spacers and ONLY one wear ring(s) (47) from each stop tube that was removed.
- 4.1.3.7 Slide the friction disc assembly onto the gear.
- 4.1.3.8 Place a release spring over every other clamp tube. Install required number of wear rings (47) and install one stop tube on every fourth stud without release springs and slide the reaction plate assembly onto the clamp tubes.

NOTE: Quantity of wear rings re-installed at each location should be same as quantity of wear spacers installed.

- 4.1.3.9 For multi-disc units, repeat steps 4.1.3.7 and 4.1.3.8 for each additional friction disc and reaction plate .
- 4.1.3.10 Slide the pressure plate and the cylinder/piston assembly onto the studs. Lubricate the threads on the end of the studs with 30 wt. oil or anti-seizing compound and install the washers (17), wear spacers (29) and the locknuts (18) removed in 4.1.3.6.
- 4.1.3.11 The wear spacers are “stored” under the locknuts and washers for use after replacing the friction discs. See Figure 9.
- 4.1.3.12 Discard un-used wear rings. Use new wear rings when replacing friction discs.
- 4.1.4 While supporting the weight of the cylinder/piston assembly, tighten the locknuts, ONE TURN AT A TIME and in an alternating (crosswise) pattern until the cylinder is seated firmly against the clamp tubes. Torque the locknuts to the appropriate value. See Table 5.



Caution:

The locknuts (18) must be tightened gradually to prevent damage to the tensioner components.

- 4.1.5 Check that clearance exists between friction discs and wear plates.
- 4.1.6 Reinstall air and coolant lines per 2.0.
- 4.2 Removal of WCB**
- 4.2.1 Disconnect the air and water supply lines.
- 4.2.2 Using lifting straps, rig the unit and remove the mounting screws from the mounting flange (1).
- 4.2.3 Slide the WCB off of the gear (28) and transport it to a clean working area placing the WCB on its mounting flange, studs (6) facing up.

4.3 Disassembly of WCB

Note: Item numbers (#) are shown on Figures 1-5.

- 4.3.1 Loosen the locknuts (18) ONE TURN AT TIME and in an alternating (crosswise) pattern until the spring force is completely relieved. Remove the locknuts and washers (17) and wear spacers (29). Mark all of the water outlet ports for identification and orientation. Deep well sockets are required. See table 10 for size and depth of socket required.
- 4.3.2 Using lifting equipment, carefully remove the cylinder (19) and piston (33) as an assembly. Set aside in a clean area.

Note: If a stud (6) should happen to come loose, remove it completely, clean the threads on the stud and the threads in the mounting flange. Apply Locquic® Primer Grade "T" to the stud threads. After the threads have dried, assemble to the mounting flange using Loctite® #262. The end of the stud must not extend past the mounting surface of the mounting flange.



Caution:

Loctite® #262 must be shaken prior to application.



Caution:

Loctite® #262 may irritate sensitive skin. Refer to the product label for proper safety precautions.

- 4.3.3 Using lifting equipment, remove the pressure plate assembly (13) and carefully place it on a suitable work surface with the wear plate (3) facing up. Do not damage the wear plate.
- 4.3.4 Remove the friction disc assembly, the reaction plate assembly (30), release springs (34), stop tubes (59) and wear rings (47) (if present) and set aside.
- 4.3.5 For multi disc units repeat step 5.2.4 for each reaction plate and friction disc set until all are removed.
- 4.3.6 Slide the clamp tubes (12) and wear spacers (29) off each of the studs.

Note: Wear limit tables for the following paragraphs are in section 6.0.

- 4.3.7 To inspect cylinder and seals refer to section 4.5.
- 4.3.8 Inspect the friction disc assemblies (7) for wear or contamination. On single and multi-disc units, the friction material must be replaced when worn to the bottom of the groove on the friction lining. See Figure 8.
- 4.3.9 For friction disc repair see section 4.4.
- 4.3.10 Inspect the wear plate (3) for wear. Wear plates must be replaced if they exceed the wear limits. See section 4.5 for repair procedures.
- 4.3.11 Inspect the reaction hole diameters in the reaction plate (30) and pressure plate (13).
- 4.3.12 Inspect the clamp tubes (12) for wear on the reaction area.
- 4.3.13 Inspect the friction disc core (9) and the gear for excessive backlash.
- 4.3.14 Inspect the release springs (34) for free height.
- 4.3.15 Re-assemble tensioner per section 4.8

4.4 Friction Lining Replacement

- 4.4.1 Friction disc cores may be relined with new friction material per the following instructions. Refer to Section 7.0 for the appropriate friction disc sub-assembly or friction disc replacement kit part number.

Note: Standard screwed on friction lining is identified with one notch, two places 180° apart, see Figure 10. High coefficient screwed on lining is identified with two notches, two places 180° apart. See Figure 11.



Caution:

Use only genuine Airflex friction material. Use of material not of Airflex origin may result in unpredictable performance.

- 4.4.2 Remove friction disc(s) per section 4.3.

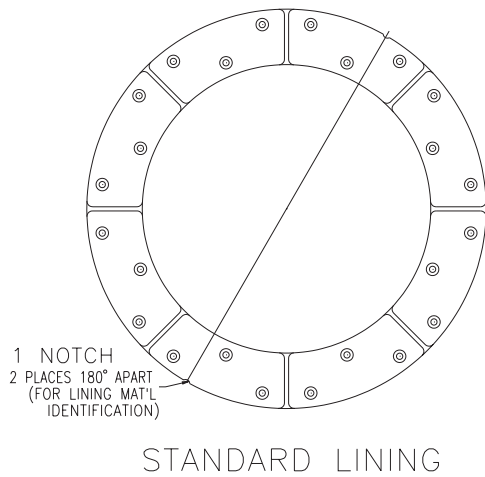

Figure 10

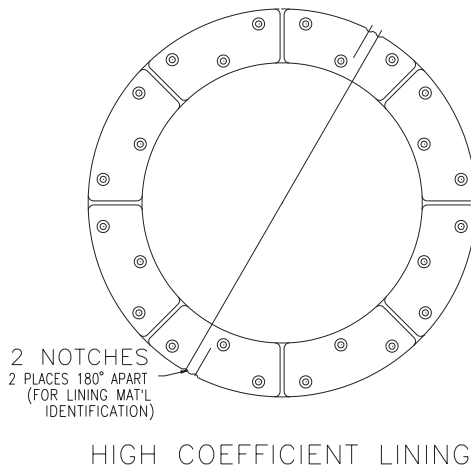

Figure 11

- 4.4.3 Remove the old screws and remove and discard the old friction material.
- 4.4.4 Clean all burrs and corrosion from the friction disc cores.
- 4.4.5 Refer to table 11 and apply specified Loctite® to screws and torque to value shown

Table 11 Friction Disc Screw Torque		
Model	18 WCB	24 & 36 WCB
Part Number	000422x0008	000421x0407
Screw Size	1/4"-28 UNRF	1/2"-13NC2
Torque	75 in. lbs.	15 ft. lbs.
Loctite®	#242	#262

! Caution:
Use only Airflex-supplied screws.

! Caution:
Loctite® #242 & #262 must be shaken prior to application.

! Caution:
Loctite® #242 & #262 may irritate sensitive skin. Refer to the product label for proper safety precautions.

4.4.6 Refer to section 4.8 for re-assembly.

4.5 Wear Plate Replacement

NOTE: Item numbers (#) are shown on Figures 1-5.

- 4.5.1 Refer to Section 7.0 for the appropriate wear plate replacement kit part number.
- 4.5.2 Remove the screws and locknuts holding the wear plates and remove the wear plates. If the wear plates cannot be easily lifted off, gently tap the O.D. to break the gasket seal.

! Caution:
Do not attempt to break the gasket seal by prying between the wear plate and housing. Damage to the sealing surfaces may occur.

- 4.5.3 Inspect the water passages and, if necessary, use a wire brush to clean them. If repainting is necessary, sand blast the water passages and paint the surfaces with Glid Gard® Epoxy 5256/5257 or equivalent. Dry film thickness should be 0.007" (0.18 mm). Be careful not to allow the paint to get into the seal grooves or onto the nubs.

! Caution:
If nubs are severely corroded, wear plates may not be properly supported. Replace pressure plate, reaction plate or mounting flange, if necessary.

4.5.4 Clean and completely dry the gasket surfaces on the pressure plate (13), reaction plate(s) (30) and mounting flange (1). These surfaces should be free of nicks and scratches to prevent leaks. Nicks and scratches may be filled with Loctite Superflex® #596 Sealant.

4.5.5 Apply a uniform bead of Loctite Superflex® #596 Sealant in the grooves of the pressure plate, reaction plate(s) and mounting flange. Recommended bead diameter is 0.060" - 0.090" (1.5 mm - 2.3 mm).

4.5.6 Inspect the new wear plates and remove any scratches or raised edges with very fine sandpaper or steel wool. Position the smoothest side of the wear plate on the mating surface being careful to align the holes.

! Caution:

Loctite Superflex® #596 Sealant will begin to set up and skin over in approximately 10 minutes. The wear plate must be fastened to the mating component within 10 minutes of applying the sealant.

4.5.7 Install the new screws and locknuts provided with the wear plate replacement kit and secure finger tight.

! Caution:

To prevent excessive warpage and to ensure a good seal, the following hardware tightening procedure must be followed.

4.5.8 For each wear plate being replaced, follow the tightening sequence shown in Figure 12 for the first 16 screws. The remaining screws may be tightened in any reasonable cross-wise pattern. See Table 12 for tightening torques.

! Caution:

Allow the Loctite Superflex® #596 Sealant 24 hours to completely cure before performing the following leak test procedure.

4.5.9 24 hours after completion of assembly, each water cavity should be checked for leaks.

Model	Size	Torque
18WCB	5/16-18NC	21 (28)
24WCB	5/16-18NC	21 (28)
36WCB	3/8-16NC2	40 (54)

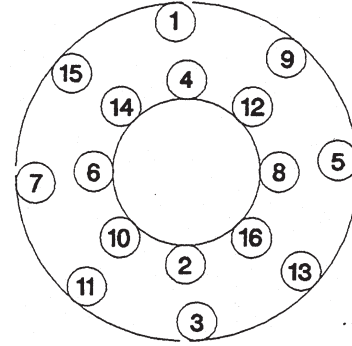

Figure 12

! Caution:

Premature pressurization may cause leaks

4.5.9.1 Using lifting straps, suspend each assembly with the water outlet port at the 12 o'clock position. Connect a water supply line to the inlet port (at 6 o'clock position). See Table 13 for water port size.

4.5.9.2 Slowly fill with water to purge all air from water cavities.

4.5.9.3 Install a pipe plug in the outlet port and apply 40 PSIG (2.7 bar) water pressure measured at the inlet. Maintain this pressure for 30 minutes.

4.5.9.4 Check for leakage at O.D. and I.D. seal areas. **NO** leakage is allowed.

4.5.9.5 If the assembly leaks, check the torque on each screw and retest. If leaks still occur, the wear plate(s) may be damaged. Repeat procedure from 4.5.4.

Model	Size
18WCB	1/2-14NPT
24WCB	3/4-14NPT
36WCB	1 1/4-11NPT

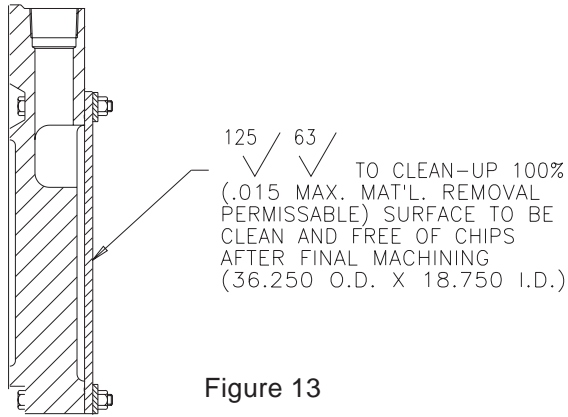

Figure 13

NOTE: New wear plates (3), on 36 WCBs, require machining after they are installed. See figure 13 for machining specifications.



Caution:
Failure to machine wear plate face could result in a reduction of torque.

4.5.10 Re-assemble per section 4.8.

4.6 Cylinder Seal Replacement

Note: Item numbers (#) are shown on Figures 1- 5.

- 4.6.1 See the Section 7.0 for the appropriate seals for each WCB tensioner.
- 4.6.2 Disconnect the air connections.
- 4.6.3 While supporting the cylinder, loosen the locknuts (18) ONE TURN AT TIME and in an alternating (crosswise) pattern until the spring force is completely relieved. Remove the locknuts and washers (17). Remove any wear spacers stored under locknuts. Mark all of the water outlet ports for identification. Deep well sockets are required. See table 10 for size and depth of socket required.
- 4.6.4 Using lifting equipment, carefully remove the cylinder (19) and piston (33) as an assembly. Set aside in a clean area.

Note: If a stud (6) should happen to come loose, remove it completely, clean the threads on the stud and the threads in the mounting flange. Apply Locquic® Primer Grade "T" to the stud threads. After the threads have dried, assemble to the mounting flange using Loctite® #262. The end of the stud must not extend past the mounting surface of the mounting flange.



Caution:
Loctite® #262 must be shaken prior to application.



Caution:
Loctite® #262 may irritate sensitive skin. Refer to the product label for proper safety precautions.

4.6.5 Place the cylinder and piston assembly with the piston facing down on blocks approximately 6" (150 mm) high. The blocks must only contact the cylinder (19) so that the piston (33) will be free to move out of the cylinder bore.

4.6.6 If a regulated air line is available, the piston can be partially ejected from the cylinder by applying no more than 15 PSIG (1.0 bar) to the cylinder.



Caution:
Application of a higher pressure may cause damage to the components.

- 4.6.7 To complete the removal of the piston from the cylinder, open all air inlets. Alternately insert a 0.50" (12 mm) diameter by 6" (150 mm) long wood dowel into each air inlet and gently tap the piston with a mallet so that it moves evenly out of the cylinder. Be careful not to damage the sealing surfaces of the piston or cylinder by cocking the piston in the cylinder.
- 4.6.8 Inspect the cylinder sealing surface condition for nicks or scratches or any other defect which may prevent the seals from being effective. Replace the cylinder, if necessary.
- 4.6.9 Noting how the lips of the seals are oriented in the piston grooves, remove the seals.
- 4.6.10 Thoroughly clean the seal grooves in the piston and apply a thin, even coat of Parker "O" Lube® to the seal grooves, the seals, the sealing surfaces of the cylinder and to the chamfer on the piston.

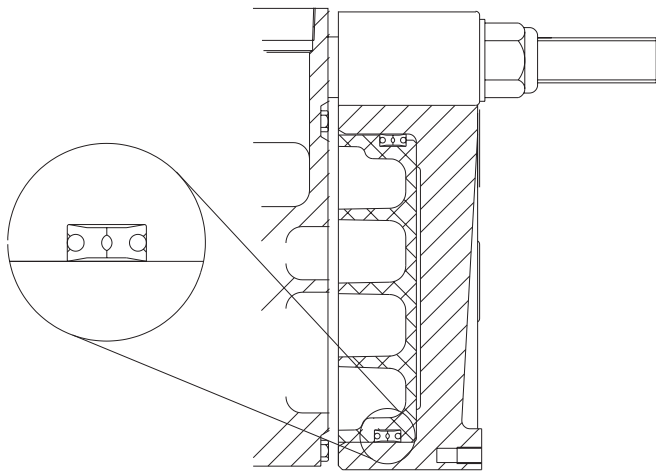

Figure 14

- 4.6.11 Install the new seals in the grooves in the piston, noting the orientation of the seals in Figure 14.
- 4.6.12 Turn the cylinder over so that the cavity faces upward.
- 4.6.13 Carefully place the piston into the cylinder with the chamfered edge of the inner diameter facing downward into the cylinder taking special care to avoid damaging the seal lips.
- 4.6.14 Gradually apply an evenly distributed force to press the piston into the cylinder being sure not to cock the piston which may damage the sealing surfaces.
- 4.6.15 Using a lifting strap, slide the cylinder/piston assembly onto the studs.
- 4.6.16 If not replacing friction disc, replace any wear spacers that were removed in 4.6.3 and install (stored) under the locknuts for use after replacing the friction discs. See Figure 9.
- 4.6.17 Lubricate the threads on the end of the studs with 30 wt. oil or anti-seizing compound and install the locknuts (18) washers (17) and the wear spacers removed.
- 4.6.18 While supporting the weight of the cylinder/piston assembly, tighten the locknuts, ONE TURN AT A TIME and in an alternating (crosswise) pattern until the cylinder is seated firmly against the clamp tubes. Torque the locknuts to the appropriate value. See Table 5.

! Caution:

The locknuts (18) must be tightened gradually to prevent damage to the tensioner components.

- 4.6.19 Connect air supply line.
- 4.6.20 Perform an air test by applying 80 PSIG (5.5 bar) to engage the tensioner. Shut off the air supply. If the air pressure does not drop below 70 PSIG (4.8 bar) after 10 minutes, the seals have been properly installed.

4.7 Bushing Replacement

- 4.7.1 Remove and dis-assemble per section 4.2 and 4.3.
- 4.7.2 Refer to Table 10 to determine if the reaction plate bushings (54) (see figure 15) require replacement. See section 7.0 for parts.
- 4.7.3 Heat up area around bushing to release Loctite® and drive old bushing out.
- 4.7.4 Clean out bores and remove old Loctite®.
- 4.7.5 Apply Loctite® #RC601, 635 or 680 to the bushing O.D. and mating hole in the reaction plate using a swab. Apply enough liquid to fill all the space between the parts. Twist the bushing while pushing it down, until it is flush with the casting surface. Inspect to see that the ring of liquid adhesive visible at the parting line. Allow reaction plate to dry for 15 minutes before moving it.
- 4.7.6 Assemble brake per section 4.8.

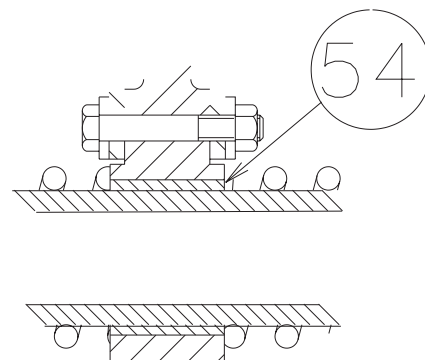

Figure 15

4.8 Assembly of WCB

Note: Item numbers (#) are shown on Figures 1-5.

- 4.8.1 Position mounting flange (1) with studs (6) installed, on a level working surface, mounting face down.
- 4.8.2 Install wear spacers (29) and clamp tubes (12) over studs.
- 4.8.3 Place the first friction disc assembly (7) onto the mounting flange.
- 4.8.4 18 and 24 WCB Models :
Place a release spring (34) over every other clamp tube. Install wear rings (47) and install stop tubes (59) on three equally spaced studs without release springs and slide the reaction plate assembly onto the clamp tubes. For single disc elements proceed to para. 4.8.6.
- 4.8.4.1 36 WCB Models:
Place a release spring (34) on all clamp tubes omitting every fourth spring. Install wear rings (47) and install stop tubes (59) every fourth clamp tube without release springs and slide the reaction plate assembly onto the clamp tubes. For single disc elements proceed to para. 4.8.6.
- 4.8.5 Place friction disc assembly onto the reaction plate.
- 4.8.5.1 Repeat steps 4.8.4 or 4.8.4.1 for each additional friction disc and reaction plate .
- 4.8.6 Slide the pressure plate and the cylinder/piston assembly onto the studs. Lubricate the threads on the end of the studs with 30 wt. oil or anti-seizing compound and install the locknuts (18) washers (17).
- 4.8.7 Tighten the locknuts, ONE TURN AT A TIME and in an alternating (crosswise) pattern until the cylinder is seated firmly against the clamp tubes. Torque the locknuts to the appropriate value. See Table 5.



Caution:

The locknuts (18) must be tightened gradually to prevent damage to the tensioner components.

- 4.8.8 Reinstall the tensioner per 2.0.

4.9 Corrosion Protection



Caution:

All previously painted areas must be touched up after maintenance or installation to provide corrosion protection.

- 4.9.1 Clean any contamination, scale, or loose paint from disturbed surfaces.
- 4.9.2 Touch up any disturbed area with an organic zinc primer.
- 4.9.3 Paint areas with two coats of a high solid two part, marine grade epoxy paint as per manufacturers instructions.

5.0 ORDERING INFORMATION/ TECHNICAL ASSISTANCE

Equipment Reference

In any correspondence regarding Airflex equipment, refer to the information on the product nameplate and call or write:

Eaton Corporation
Airflex Division
9919 Clinton Rd.
Cleveland, Ohio 44144
Inside the U.S.A and Canada: 800-233-5926
Outside the U.S.A and Canada: (216)-281-2211
Fax: (216) 281-3890

Loctite, Locquic, Permaflex and Superflex are registered trademarks of Loctite Corporation.
Polypak and Parker O-Lube are registered trademarks of Parker Hannifin Corporation.
Glid Gard is a registered trademark of The Glidden Company.
Molub-Alloy is a registered trademark of Castrol Industrial, Performance Lubricants Division.

6.0 WEAR LIMITS

Table 14			
Wear Limits for WCB Components			
Item	Description	Wear Limit	Remarks
#8 Friction Disc	Friction Material	Fully worn at bottom of dust groove. See Figure 5. Friction material must also be replaced if contaminated with oil or grease.	Multi-disc units have adjustment provision. See 4.2.
#3 Wear Plate	Friction Wear Surface	Maximum wear is: 18 WCB 0.030" 24 WCB 0.045" 36 WCB 0.050"	Wear will be in form of circular grooves in copper surface.
#19 Cylinder	Seal Area	Maximum wear is 0.005" (0.13 mm).	Wear will be in the form of grooves where the seals contact.
#14 Pressure Plate	Bushing Reaction Holes	Maximum wear is 0.031" (0.80 mm).	Wear will be in the form of elongation of the holes. Original hole diameters are shown in Table 8A.
#31 Reaction Plate	Bushing Reaction Holes	Maximum wear is 0.031" (0.80 mm).	Wear will be in the form of elongation of the holes. Original hole diameters are shown in Table 8A.
#12 Clamp Tube	Reaction Area	Maximum wear is 0.015" (0.38 mm).	Wear will be in the form of a notch or step on the side of the tube.
#9 & #28 Friction Disc Core and Gear	Gear Backlash	Maximum allowable total backlash is 0.040" (1.0 mm).	If step is worn in gear, gear must be replaced.

Table 15	
Original Reaction Hole Bushing Diameters In Pressure Plate and Reaction Plate (Item 53 on Figure 15)	
Size	Diameter - In. (mm)
18WCB	1.312 (33.33)
24WCB	1.688 (42.88)
36WCB*	2.060 (52.32)

Table 16		
(Item 34, Figures 1 - 3.)		
Model	Original Release Spring free height in. (mm)	Minimum Release Spring free height in. (mm)
18 WCB	2.84 (72.14)	1.65 (41.91)
24 WCB	3.45 (87.63)	2.59 (65.79)
36 WCB	4.46 (113.280)	2.66 (67.56)

Table 17	
Original Friction Disc Wear Groove Depth	
Model	Depth - in. (mm)
18 WCB	.250" (6.3)
24 WCB	.250" (6.3)
36 WCB	.210" (5.3)

7.0 PARTS

118 WCB		146308AJ (514387)		146308AK	
Item	Description	Part Number	Quantity	Part Number	Quantity
1	Mounting Flange Sub-assembly	514143-01	1	514143-01	1
3	Wear Plate	412953	2	412953	2
6	Stud	308139-04	12	308139-04	12
7	Friction Disc Sub-assembly	514172	1	N/A	1
8	Friction Disc	513657	2	513680	2
9	Friction Disc Core	514145	1	514145	1
12	Clamp Tube	308207-04	12	308207-04	12
13	Pressure Plate Sub-assembly	514143-03	1	514143-03	1
17	Flat Washer	000153x0727	12	000153x0727	12
18	Locknut	000110x0070	12	000110x0070	12
19	Cylinder	514017	1	514017	1
21	Polypak Seal	000402x0021	2	000402x0021	2
23	Polypak Seal	000402x0022	2	000402x0022	2
24	Warning Decal	203627	1	203627	1
25	Name Plate	308284	1	308284	1
26	Screw	000153x0644	8	000153x0644	8
28	Gear	308216	1	308216	1
29	Wear Spacer	N/A	N/A	N/A	N/A
30	Reaction Plate Sub-assembly	N/A	N/A	N/A	N/A
32	Decal Plate	307753	1	307753	1
33	Piston	514389	1	514389	1
34	Release Spring	308138	6	308138	6
47	Wear Ring	N/A	N/A	N/A	N/A
54	Pressure Plate Bushing	204114-02	12	204114-02	12
	Reaction Plate Bushing	N/A	N/A	N/A	N/A
57	Flat Head Screw	000422x0008	48	000422x0008	48
59	Stop Tube	308289-01	3	308289-01	3
105	Brass Plug	000077x0021	1	000077x0021	1

218 WCB		146310AJ (514398)		146310AK	
Item	Description	Part Number	Quantity	Part Number	Quantity
1	Mounting Flange Sub-assembly	514143-01	1	514143-01	1
3	Wear Plate	412953	4	412953	4
6	Stud	308139-05	12	308139-05	12
7	Friction Disc Sub-assembly	514172	2	N/A	2
8	Friction Disc	513657	4	513680	4
9	Friction Disc Core	514145	2	514145	2
12	Clamp Tube	308207-05	12	308207-05	12
13	Pressure Plate Sub-assembly	514143-03	1	514143-03	1
17	Flat Washer	000153x0727	12	000153x0727	12
18	Locknut	000110x0070	12	000110x0070	12
19	Cylinder	514017	1	514017	1
21	Polypak Seal	000402x0021	2	000402x0021	2
23	Polypak Seal	000402x0022	2	000402x0022	2
24	Warning Decal	203627	1	203627	1
25	Name Plate	308284	1	308284	1
26	Screw	000153x0644	8	000153x0644	8
28	Gear	308208	1	308208	1
29	Wear Spacer	308201-02	12	308201-02	12
30	Reaction Plate Sub-assembly	514143-02	1	514143-02	1
32	Decal Plate	307753	1	307753	1
33	Piston	514389	1	514389	1
34	Release Spring	308138	12	308138	12
47	Wear Ring	308289-03	6	308289-03	6
54	Pressure Plate Bushing	204114-02	12	204114-02	12
	Reaction Plate Bushing	204114-04	12	204114-04	12
57	Flat Head Screw	000422x0008	96	000422x0008	96
59	Stop Tube	308289-02	6	308289-02	6
105	Brass Plug	000077x0021	1	000077x0021	1

124 WCB		146313AJ		146313AK (514246)	
Item	Description	Part Number	Quantity	Part Number	Quantity
1	Mounting Flange Sub-assembly	514130-01	1	514130-01	1
3	Wear Plate	508459	2	508459	2
6	Stud	308160-07	12	308160-07	12
7	Friction Disc Sub-assembly	514131	1	514147	1
8	Friction Disc	508725	2	512825	2
9	Friction Disc Core	514140	1	514140	1
12	Clamp Tube	308206-05	12	308206-05	12
13	Pressure Plate Sub-assembly	514130-03	1	514130-03	1
17	Flat Washer	000153x0854	12	000153x0854	12
18	Locknut	000110x0076	12	000110x0076	12
19	Cylinder	514039	1	514039	1
21	Polypak Seal	000402x0023	2	000402x0023	2
23	Polypak Seal	000402x0024	2	000402x0024	2
24	Warning Decal	203627	1	203627	1
25	Name Plate	308284	1	308284	1
26	Screw	000153X0644	8	000153X0644	8
28	Gear	416454	1	416454	1
29	Wear Spacer	N/A	N/A	N/A	N/A
30	Reaction Plate Sub-assembly	N/A	N/A	N/A	N/A
32	Decal Plate	307753	1	307753	1
33	Piston	513924	1	513924	1
34	Release Spring	308212	6	308212	6
47	Wear Ring	N/A	N/A	N/A	N/A
54	Pressure Plate Bushing	203866-01	12	203866-01	12
	Reaction Plate Bushing	N/A	N/A	N/A	N/A
57	Flat Head Screw	000421x0407	36	000421x0407	36
59	Stop Tube	308213-05	3	308213-05	3
105	Brass Plug	000077x0021	1	000077x0021	1

224 WCB		146339AJ (514195)		146339AK (514196)	
Item	Description	Part Number	Quantity	Part Number	Quantity
1	Mounting Flange Sub-assembly	514130-01	1	514130-01	1
3	Wear Plate	508459	4	508459	4
6	Stud	308160-05	12	308160-05	12
7	Friction Disc Sub-assembly	514131	2	514147	2
8	Friction Disc	508725	4	512825	4
9	Friction Disc Core	514140	2	514140	2
12	Clamp Tube	308206-01	12	308206-01	12
13	Pressure Plate Sub-assembly	514130-03	1	514130-03	1
17	Flat Washer	000153x0854	12	000153x0854	12
18	Locknut	000110x0076	12	000110x0076	12
19	Cylinder	514039	1	514039	1
21	Polypak Seal	000402x0023	2	000402x0023	2
23	Polypak Seal	000402x0024	2	000402x0024	2
24	Warning Decal	203627	1	203627	1
25	Name Plate	308284	1	308284	1
26	Screw	000153x0644	8	000153x0644	8
28	Gear	416439	1	416439	1
29	Wear Spacer	308193-02	12	308193-02	12
30	Reaction Plate Sub-assembly	514130-02	1	514130-02	1
32	Decal Plate	307753	1	307753	1
33	Piston	513924	1	513924	1
34	Release Spring	308212	12	308212	12
47	Wear Ring	308213-04	6	308213-04	6
54	Pressure Plate Bushing	203866-01	12	203866-01	12
	Reaction Plate Bushing	203866-04	12	203866-04	12
57	Flat Head Screw	000294x0407	72	000294x0407	72
59	Stop Tube	308213-02	6	308213-02	6
105	Brass Plug	000077x0021	1	000077x0021	1

236 WCB		146338AJ		146338AK (514082)	
Item	Description	Part Number	Quantity	Part Number	Quantity
1	Mounting Flange Sub-assembly	513284-01	1	513284-01	1
3	Wear Plate	414026	4	414026	4
6	Stud	307111-10	16	307111-10	16
7	Friction Disc Sub-assembly	514128	2	514128	2
8	Friction Disc	513675	32	513675	32
9	Friction Disc Core	513667	2	513667	2
12	Clamp Tube	308204-02	16	308204-02	16
13	Pressure Plate Sub-assembly	513284-03	1	513284-03	1
17	Flat Washer	000067x0042	16	000067x0042	16
18	Locknut	000110x0075	16	000110x0075	16
19	Cylinder	512809	1	512809	1
21	Polypak Seal	000402x0005	2	000402x0005	2
23	Polypak Seal	000402x0006	2	000402x0006	2
24	Warning Decal	203627	1	203627	1
25	Name Plate	307640	1	307640	1
26	Screw	000153x0644	8	000153x0644	8
28	Gear	416445	1	416445	1
29	Wear Spacer	308191-04	16	308191-04	16
30	Reaction Plate Sub-assembly	513284-02	1	513284-02	1
32	Decal Plate	307753	2	307753	2
33	Piston	513872	1	513872	1
34	Release Spring	307175	24	307175	24
47	Wear Ring	308190-06	8	308190-06	8
54	Pressure Plate Bushing	203863-04	16	203863-04	16
	Reaction Plate Bushing	203863-03	16	203863-03	16
57	Flat Head Screw	000421x0407	288	000421x0407	288
59	Stop Tube	308190-03	8	308190-03	8
105	Brass Plug	N/A	N/A	N/A	N/A

336 WCB		146289BJ (514239)		146289BK (514238)	
Item	Description	Part Number	Quantity	Part Number	Quantity
1	Mounting Flange Sub-assembly	513284-01	1	513284-01	1
3	Wear Plate	414026	6	414026	6
6	Stud	307111-05	16	307111-05	16
7	Friction Disc Sub-assembly	514129	3	514128	3
8	Friction Disc	513658	48	513675	48
9	Friction Disc Core	514139	3	513667	3
12	Clamp Tube	308204-04	16	308204-04	16
13	Pressure Plate Sub-assembly	513284-03	1	513284-03	1
17	Flat Washer	000153x0850	16	000067x0042	16
18	Locknut	000110x0075	16	000110x0075	16
19	Cylinder	512809	1	512809	1
21	Polypak Seal	000402x0005	2	000402x0005	2
23	Polypak Seal	000402x0006	2	000402x0006	2
24	Warning Decal	203627	1	203627	1
25	Name Plate	307640	1	307640	1
26	Screw	000153x0644	8	000153x0644	8
28	Gear	416435	1	416435	1
29	Wear Spacer	308191-04	32	308191-04	32
30	Reaction Plate Sub-assembly	513284-02	2	513284-02	2
32	Decal Plate	307753	2	307753	2
33	Piston	513872	1	513872	1
34	Release Spring	307175	36	307175	36
47	Wear Ring	308190-05	24	308190-05	24
54	Pressure Plate Bushing	203863-04	16	203863-04	16
	Reaction Plate Bushing	203863-03	16	203863-03	16
57	Flat Head Screw	000421x0407	432	000421x0407	432
59	Stop Tube	308190-03	12	308190-03	12
105	Brass Plug	N/A	N/A	N/A	N/A

Wear Plate Kits

Model	Kit Part Number	Quantity Each	Description	Part Number
18WCB Basic Kit	107726N	160	Locknut	000153x0642
		160	Screw	000153x0726
		1	Loctite® Superflex	000153x1071
		1	Instruction Sheet	204063
		2	Wear Plate	412953
		8	Inner Ring	413105-01
		8	Outer Ring	413106-01
18WCB Reaction Plate Kit	107726O	80	Locknut	000153x0642
		80	Screw	000153x1071
		1	Loctite® Superflex	000153x1071
		1	Instruction Sheet	204063
		2	Wear Plate	412953
		8	Inner Ring	413105-01
		8	Outer Ring	413106-01
24WCB Basic Kit	107727N	180	Locknut	000153x0642
		180	Screw	000153x0685
		1	Loctite® Superflex	000153x1071
		1	Instruction Sheet	204063
		6	Inner Ring	413107-01
		10	Outer Ring	413108-01
		2	Wear Plate	508459
24WCB Reaction Plate Kit	107727O	90	Locknut	000153x0642
		90	Screw	000153x0685
		1	Loctite® Superflex	000153x1071
		1	Instruction Sheet	204063
		6	Inner Ring	413107-01
		10	Outer Ring	413108-01
		2	Wear Plate	508459
36WCB Basic Kit	107662N	216	Screw	000153x0842
		216	Locknut	000153x0844
		2	Loctite® Superflex	000153x1071
		1	Instruction Sheet	204063
		2	Wear Plate	414026
		12	Inner Ring	414032-01
		18	Outer Ring	414033-01

Cylinder Seal Kits

Size	Part Number	Large seal	Small seal
18WCB	107726C	000402X0022 2 EACH	000402X0021 2 EACH
24WCB	107727C	000402X0024 2 EACH	000402X0023 2 EACH
36WCB	107662C	000402X0006 2 EACH	000402X0005 2 EACH

All Kits include 1 each - Instruction Sheet (P/N204067) and 4oz tube of Parker O-Lube (P/N000153x0881).

EATON PRODUCT WARRANTY

Subject to the conditions stated herein, Eaton Corporation warrants to the Purchaser that each new Airflex Product manufactured by Eaton will be free from failures caused by defects in material and workmanship, and will deliver its rated capacity, for a period of twelve (12) months from the date of shipment to Purchaser, provided such Product is properly installed, properly maintained, operated under normal conditions and with competent supervision. Warranty claims shall be made in writing and the part or parts shall, if requested by Airflex Division, be returned prepaid to the Airflex Division for inspection. Upon a determination that a defect exists, Eaton shall thereupon correct any defect, at its option either by repairing any defective part or parts or by making available at Eaton's plant a repaired or replacement part. This warranty does not extend to normal wear parts or components of the Product, such as friction material and friction surfaces.

LIMITATION OF WARRANTY

THE FOREGOING WARRANTY IS EXCLUSIVE AND IN LIEU OF ALL OTHER WARRANTIES WHETHER WRITTEN, ORAL OR IMPLIED. ANY IMPLIED WARRANTY OF MERCHANTABILITY OR FITNESS FOR A PARTICULAR PURPOSE ARE SPECIFICALLY EXCLUDED.

In no event shall Eaton be liable for special, incidental or consequential damages. Eaton's liability arising out of the supplying of such Product, or its use, whether in warranty, contract or otherwise, shall in no case exceed the cost of correcting defects in the Products as herein provided. Upon expiration of the twelve (12) month period, all such liability shall terminate. THE FOREGOING SHALL CONSTITUTE THE SOLE REMEDY OF PURCHASER AND THE SOLE LIABILITY OF EATON.