

## Description and Technical Data

### Description

The 21DCB combination clutch/brake package was specifically designed for the can making industry to withstand the cyclic impact loads associated with high speed can extruding machinery. A patented quick release air manifold provides fast clutch/brake response; stopping the ram to prevent die damage due to material misfeed.

The unit is ideally suited for high speed continuously running machinery requiring an extremely fast stop.

The package consists of an air-actuated disc clutch and a spring-applied disc brake. The clutch disc is guided axially at its outside diameter by a series of bushings which attach to the driving flywheel. The brake disc is reacted to the machine frame by two reaction arms. The housing hub is pressed on and keyed to the driven shaft.

When the cylinder is pressurized, the piston clamps the clutch disc to the hub, transmitting torque to the shaft. When the cylinder exhausts, springs move the piston in the opposite direction, clamping the brake disc and stopping the shaft. Overlapping cannot occur between clutching and braking.

### Notes:

- ① Ratings are for worn in new linings. Decrease ratings 12% for worn linings.
- ② Maximum speed for non-cyclic operation. Maximum speed for single stroke operation is dependent upon thermal requirements. Dynamic balancing required for operating speeds over 750 rpm.
- ③ Absolute volume required per engagement.

### Technical Data

#### Torque Rating $M_r$ <sup>①</sup> at 85 psi (5,9 bar)

Clutch static torque: 75000 lb-in (8475 N-m)

Brake dynamic torque: 55000 lb-in (6215 N-m)

#### Operating Pressure

Maximum allowable pressure  $p_r$ : 85 psi (5,9 bar)

Brake releasing pressure  $p_s$  : 38 psi (2,6 bar)

#### Maximum Speed<sup>②</sup>

1000 rpm

#### Inertia

Housing : 90 lb-ft<sup>2</sup> (3,8 kg-m<sup>2</sup>)

Clutch disc : 18 lb-ft<sup>2</sup> (0,76 kg-m<sup>2</sup>)

#### Weight

Housing and manifold: 290 lb (130 kg)

Each friction disc : 52 lb (24 kg)

#### Air Cylinder Volume<sup>③</sup>

With new linings : 55 in<sup>3</sup> (0,8 dm<sup>3</sup>)

With worn linings: 80 in<sup>3</sup> (1,3 dm<sup>3</sup>)

#### Brake Response to Full Torque

With new linings : 0.035 sec

With worn linings: 0.045 sec

#### Thermal Capacity

Non-Cyclic: 400000 ft-lb (542400 J)

Cyclic:

100 rpm: 1.5 HP (1,1 kW)

300 rpm: 2.1 HP (1,6 kW)

500 rpm: 2.6 HP (1,9 kW)

700 rpm: 3.1 HP (2,3 kW)

900 rpm: 3.4 HP (2,5 kW)

**Authorized Distributor**

**MIDWEST  
BRAKE**

26255 Groesbeck Hwy.  
Warren, MI 48089 U.S.A.  
586.775.3000 • 586.775.3040 (Fax)  
sales@midwestbrake.com  
www.midwestbrake.com

**Eaton<sup>®</sup> Airflex<sup>®</sup> Clutches & Brakes**

## Dimensional Data

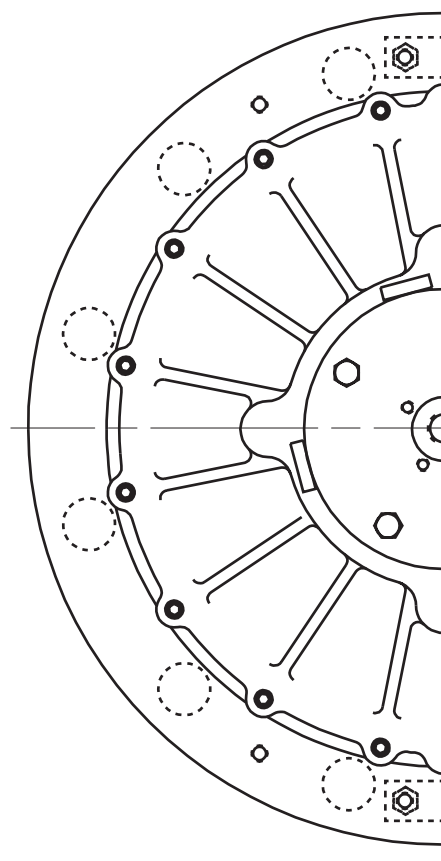
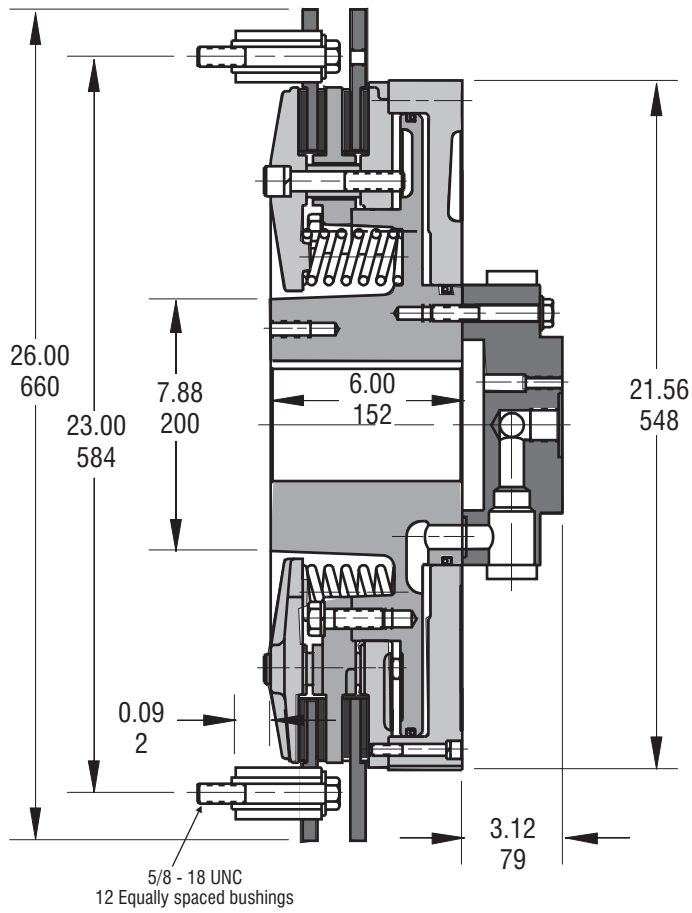

Maximum bore - 5.50 (140mm)

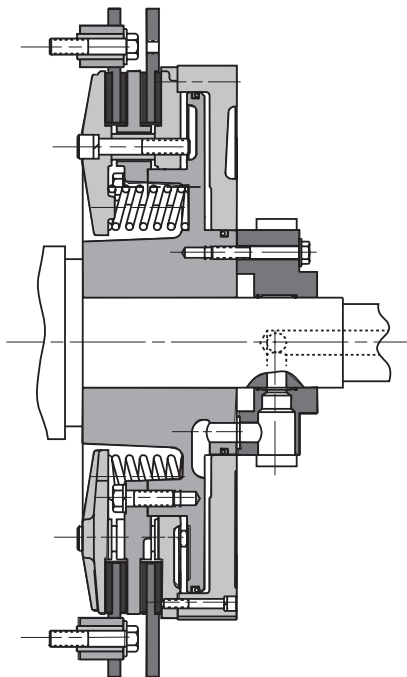

Typical through shaft mounting

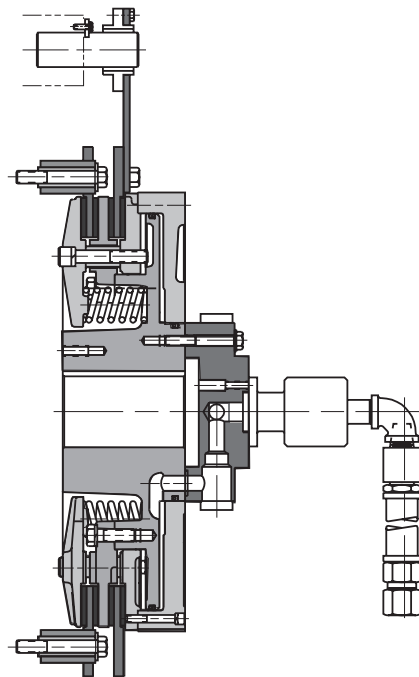

Typical shaft end mounting